

Manual for Induction Motors and Generators



Safety Instructions

AMA, AMB, AMG, AMH, AMI, AMK, AMZ, HXR, M3BM, M3GM

1. General

General safety regulations, specific agreements made for each work site and safety precautions shown in this document must be observed at all times.

2. Intended use

Electric machines have dangerous live and rotating parts and may have hot surfaces. All operations serving transport, storage, installation, connection, commissioning, operation and maintenance shall be carried out by responsible skilled persons (in conformity with EN 50 110-1 / DIN VDE 0105 / IEC 60364). Improper handling may cause serious personal injury and damage to property. **Danger!**

These machines are intended for industrial and commercial installations as components as defined in the Machinery Directive (MD) 98/37/EC. Commissioning is prohibited until conformity of the end product with this directive has been established (follow particular local safety and installation rules as, for example, EN 60204).

These machines comply with the harmonized series of standards EN 60034 / DIN VDE 0530. Their use in explosive atmosphere is prohibited unless they are expressly designed for such use (follow additional instructions).

On no account, use degrees of protection \leq IP23 outdoors. Air-cooled models are typically designed for ambient temperatures of -20°C up to $+40^{\circ}\text{C}$ and altitudes of \leq 1000 m above sea level. Ambient temperature for air-/water-cooled models should be not less than $+5^{\circ}\text{C}$ (for sleeve-bearing machines, see manufacturer's documentation). By all means, take note of deviating information on the rating plate. Field conditions must conform to all rating plate markings.

3. Transport, storage

Immediately report damage established after delivery to transport company. Stop commissioning, if necessary. Lifting eyes are dimensioned for the weight of the machine, do not apply extra loads. Ensure the use of correct lifting eyes. If necessary, use suitable, adequately dimensioned means of transport (for example, rope guides). Remove shipping braces (for example, bearing locks, vibration dampers) before commissioning. Store them for further use.

When storing machines, make sure of dry, dust and vibration free location (danger of bearing damage at rest). Measure insulation resistance before commissioning. At values of \leq 1 k Ω per volt of rated voltage, dry winding. Follow the manufacturer's instructions.

4. Installation

Make sure of even support, solid foot or flange mounting and exact alignment in case of direct coupling. Avoid resonances with rotational frequency and double mains frequency as a result of assembly. Turn rotor and listen for abnormal slip noises. Check direction of rotation in uncoupled state.

Follow the manufacturer's instructions when mounting or removing couplings or other drive elements and cover them with a touch guard. For trial run in uncoupled state, lock or remove the shaft end key. Avoid excessive radial and axial bearing loads (note manufacturer's documentation). The balance of the machine is indicated as H = Half and F = Full key. In half-key cases, the coupling too, must be half-key balanced. In case of protruding, visible part of the shaft end key, establish mechanical balance.

Make necessary ventilation and cooling system connections. The ventilation must not be obstructed and the exhaust air, also of neighbouring sets, not taken in directly.

5. Electrical connection

All operations must be carried out only by skilled persons on the machine at rest. Before starting work, the following safety rules must be strictly applied:

- De-energize!
- Provide safeguard against reclosing!
- Verify safe isolation from supply!
- Connect to earth and short!
- Cover or provide barriers against neighbouring live parts!
- De-energize auxiliary circuits (for example, anti-condensation heating)!

Exceeding of limit values of zone A in EN 60034-1 / DIN VDE 0530-1 - voltage $\pm 5\%$, frequency $\pm 2\%$, waveform and symmetry -leads to higher temperature rise and affects the electromagnetic compatibility. Note rating plate markings and connection diagram in the terminal box.

The connection must be made in a way that the permanent safe electrical connection is maintained. Use appropriate cable terminals. Establish and maintain safe equipotential bonding.

The clearances between uninsulated live parts and between such parts and earth must not be below the values of appropriate standards and values possibly given in manufacturer's documentation.

No presence of foreign bodies, dirt or moisture is allowed in the terminal box. Close unused cable entrance holes and the box itself in a dust- and watertight manner. Lock the key when the machine is run without coupling. For machines with accessories, check satisfactory functioning of these before commissioning.

The proper installation (for example, segregation of signal and power lines, screened cables etc.) lies within the installer's responsibility.

6. Operation

Vibration severity in the "satisfactory" range ($V_{\text{rms}} \leq 4.5$ mm/s) according to ISO 3945 is acceptable in coupled-mode operation. In case of deviations from normal operation - for example, elevated temperature, noises, vibrations - disconnect machine, if in doubt. Establish cause and consult manufacturer, if necessary.

Do not defeat protective devices, not even in trial run. In case of heavy dirt deposits, clean cooling system at regular intervals. Open blocked condensate drain holes from time to time.

Grease the bearings during commissioning before start-up. Regrease antifriction bearings while the machine is running. Follow instructions on lubrication plate. Use right kind of grease. In

case of sleeve-bearing machines, observe time-limit for oil-change and if equipped with oil supply system make sure the system is working.

7. Maintenance and servicing

Follow the manufacturer's operating instructions. For further details, see the comprehensive User's Manual. Preserve these safety instructions!

8. Frequency converter

In frequency converter applications motor frame external earthing must be used for equalising the potential between the motor frame and the driven machine, unless the two machines are mounted on the same metallic base. For motor frame sizes over IEC 280, use 0.75 x 70 mm flat conductor or at least two 50 mm² round conductors. The distance of the round conductors must be at least 150 mm from each other.

This arrangement has no electrical safety function; the purpose is to equalise the potentials. When the motor and the gearbox are mounted on a common steel fundament, no potential equalisation is required.

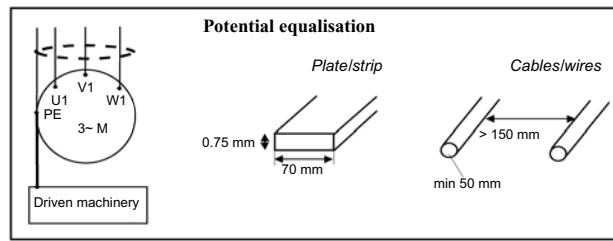

To comply with EMC-requirements, use only cables and connectors approved for this purpose. (See instruction for frequency converters.)

Additional Safety Instructions for Permanent Magnet Synchronous Machines

Electrical connection and operation

When the machine shaft is rotating, a permanent magnet synchronous machine induces voltage to the terminals. The induced voltage is proportional to the rotational speed, and can be hazardous even at low speeds. Prevent any rotation of the shaft before opening the terminal box and/or working at the unprotected terminals.

WARNING: The terminals of a machine with frequency converter supply may be energized even when the machine is at a standstill.

WARNING: Beware of reverse-power when working at the supply system.

WARNING: Do not exceed the maximum allowed speed of the machine. See product specific manuals.

Maintenance and servicing

Permanent magnet synchronous machines must only be serviced by repair shops qualified and authorised by ABB. For more information concerning service of permanent magnet synchronous machines, please contact ABB.

WARNING: Only qualified personnel familiar with the relevant safety requirements are allowed to open and maintain permanent magnet synchronous machines.

WARNING: It is not allowed to remove the rotor of a permanent magnet synchronous machine without the special tools designed for this purpose.

WARNING: Magnetic stray fields, caused by an open or disassembled permanent magnet synchronous machine or by a separate rotor of such a machine, may disturb or damage other electrical or electromagnetic equipment and components, such as cardiac pacemakers, credit cards and equivalent.

WARNING: Loose metallic parts and waste must be prevented from entering the interior of the permanent magnet synchronous machine as well as getting into contact with the rotor.

WARNING: Before closing an opened permanent magnet synchronous machine, all parts which does not belong to the machine and wastes must be removed from the interior of the machine.

NOTE: Beware of magnetic stray fields and possible induced voltages when rotating the separate rotor of a permanent magnet synchronous machine as they may cause damage to surrounding equipment, for example lathes or balancing machines.



Additional Safety Instructions for Electrical Motors for Explosive Atmosphere

NOTE: These instructions must be followed to ensure safe and proper installation, operation and maintenance of the motor. They should be brought to the attention of anyone who installs, operates or maintains this equipment. Ignoring the instruction may invalidate the warranty.

WARNING: Motors for explosive atmosphere are specially designed to comply with official regulations concerning the risk of explosion. If improperly used, badly connected, or altered, no matter how minor, their reliability could be in doubt.

Standards relating to the connection and use of electrical apparatus in explosive atmosphere must be taken into consideration, especially national standards for installation. (see standards: EN 60079-14, EN 60079-17, EN 61241-14, EN 61241-17 IEC 60079-14, IEC 60079-17, IEC 61241-14 and IEC 61241-17). All repairs and overhauls must be carried out according to the standard IEC 60079-19. Only trained personnel familiar with these standards should handle this type of apparatus.

Declaration of Conformity

All ABB Ex-machines intended for explosive atmosphere comply with the ATEX Directive 94/9/EC and have a CE-mark on the rating plate.

Validity

These instructions are valid for the following ABB Oy's electrical motor types, when the machine is used in explosive atmosphere.

Non-sparking Ex nA, Class I Div 2, Class I Zone 2

- AMA Induction Machines, sizes 315 to 500
- AMB Induction Machines, sizes 560 to 630
- AMI Induction Machines, sizes 560 to 630
- HXR Induction Machines, sizes 315 to 560
- AMZ Synchronous Machines, sizes 710 to 2500
- M3GM Induction Machines, sizes 315 to 450

Increased safety Ex e

- AMA Induction Machines, sizes 315 to 500
- AMB Induction Machines, sizes 560 to 630
- AMI Induction Machines, sizes 560 to 630
- HXR Induction Machines, sizes 315 to 560

Pressurisation Ex pxe, Ex pze, Ex px, Ex pz

- AMA Induction Machines, sizes 315 to 500
- AMB Induction Machines, sizes 560 to 630
- AMI Induction Machines, sizes 560 to 630
- HXR Induction Machines, sizes 315 to 560
- AMZ Synchronous Machines, sizes 710 to 2500

Dust Ignition Protection (DIP), Ex tD, Class II Div 2, Class II Zone 22, Class III

- AMA Induction Machines, sizes 315 to 500
- AMB Induction Machines, sizes 560 to 630
- AMI Induction Machines, sizes 560 to 630
- HXR Induction Machines, sizes 315 to 560
- M3GM Induction Machines, sizes 315 to 450

(Additional information may be required for some machine types used in special applications or with special design.)

Conformity according to standards

As well as conforming to the standards relating to mechanical and electrical characteristics, motors designed for explosive atmospheres must also conform to the following IEC or EN standards:

EN 60079-0;	Std. concerning General Requirements for Explosive Atmospheres
EN 60079-2;	Std. concerning Ex p protection
EN 60079-7;	Std. concerning Ex e protection
EN 60079-15;	Std. concerning Ex nA protection
EN 61241-1;	Std. concerning combustible dust, Ex tD protection
IEC 60079-0;	Std. concerning General Requirements for Explosive Atmospheres
IEC 60079-2;	Std. concerning Ex p protection
IEC 60079-7;	Std. concerning Ex e protection
IEC 60079-15;	Std. concerning Ex nA protection
IEC 61241-0;	Std. concerning General Requirements for combustible dust
IEC 61241-1;	Std. concerning combustible dust, Ex tD protection
NFPA 70;	National Electric Code (NEC)
C 22-1-98;	Canadian Electrical Code, Part I (CE Code)

ABB machines (valid only for group II) can be installed in areas corresponding to following marking:

Zone (IEC)	Category (EN)	Marking
1	2	Ex px, Ex pxe, Ex e
2	3	Ex nA, Ex N, Ex pz, Ex pze

Atmosphere (EN);

G - explosive atmosphere caused by gases

D - explosive atmosphere caused by dust

Incoming inspection

- Immediately upon receipt check the machine for external damage and if found, inform the forwarding agent without delay.
- Check all rating plate data, especially voltage, winding connection (star or delta), category, type of protection and temperature marking.

Notice following rules during any operations!

WARNING: Disconnect and lock out before working on the machine or the driven equipment. Ensure no explosive atmosphere is present while the work is in progress.

Starting and Re-starting

- The maximum number of the sequential starts has been declared in machine's technical documents.
- The new starting sequence is allowed after the machine has cooled to the ambient temperature (-> cold starts) or to operating temperature (-> warm starts).

Earthing and Equipotentialing

- Check before starting that all earthing and equipotentialing cables are effectively connected.
- Do not remove any earthing or equipotentialing cables, which has been assembled by the manufacturer.

Clearances, creepage distances and separations

- Do not make any removal or adjustment in terminal boxes, which could decrease clearances or creepage distances between any parts.
- Do not install any new equipment to terminal boxes without asking for advises from ABB Oy.
- Be sure that air gap between rotor and stator is measured after any maintenance for the rotor or bearings. The air gap shall be the same in any point between stator and rotor.
- Centralize the fan to the center of the fanhood or the air guide after any maintenance. The clearance shall be at least 1% of the maximum diameter of the fan and in accordance with standards.

Connections in terminal boxes

- All connections in main terminal boxes must be made with Ex-approved connectors, which are delivered with the machine by the manufacturer. In other cases ask an advice from ABB Oy.
- All connections, in auxiliary terminal boxes, as marked intrinsically safe circuits (Ex i or EEx i) must be connected to proper safety barriers.

Space heaters

- If an anti-condensation heater, without self-regulation, is turned on immediately after the motor is shut down, take suitable measures to control the inside motor housing temperature. The anti-condensation heaters can only operate within a temperature-controlled environment.

Pre-start ventilation

- Ex nA and Ex e machines may, or in some cases, have to be equipped with a provision for pre-start ventilation.
- Before starting, check the need to purge the machine enclosure to make sure that the enclosure is free of flammable gases. Based on the risk assessment, the customer and/or the local authorities will make the decision, whether the customer needs to use the pre-start ventilation or not.

NOTE: If there are any conflicts between these safety instructions and the user manual, these safety instructions are prevailing.

Chapter 1 - Introduction

1.1	General information.....	1
1.2	Important note.....	1
1.3	Limitation of liability.....	2
1.4	Documentation.....	2
1.4.1	Documentation of the machine.....	2
1.4.2	Information not included in documentation.....	3
1.4.3	Units used in this User's Manual.....	3
1.5	Identification of the machine.....	3
1.5.1	Serial number of the machine.....	3
1.5.2	Rating plate.....	3

Chapter 2 - Transport and Unpacking

2.1	Protective measures prior to transport.....	6
2.1.1	General.....	6
2.1.2	Bearing plate.....	6
2.2	Lifting the machine.....	8
2.2.1	Lifting a machine in a seaworthy package.....	8
2.2.2	Lifting a machine on a pallet.....	9
2.2.3	Lifting an unpacked machine.....	10
2.3	Turning a vertically mounted machine.....	11
2.4	Checks upon arrival and unpacking.....	12
2.4.1	Check upon arrival.....	12
2.4.2	Check upon unpacking.....	12
2.5	Installation instructions for main terminal box and cooler parts.....	12
2.5.1	Installation of main terminal box.....	12
2.5.2	Installation of cooler parts.....	13
2.6	Storage.....	13
2.6.1	Short term storage (less than 2 months).....	13
2.6.2	Long term storage (more than 2 months).....	14
2.6.3	Rolling bearings.....	15
2.6.4	Sleeve bearings.....	17
2.6.5	Openings.....	18
2.7	Inspections, records.....	18

Chapter 3 - Installation and Alignment

3.1	General.....	19
3.2	Foundation design.....	19
3.2.1	General.....	19
3.2.2	Forces to the foundation.....	20
3.2.3	Flanges for vertically mounted machines.....	20
3.3	Machine preparations before installation.....	20
3.3.1	Insulation resistance measurements.....	20
3.3.2	Disassembly of the transport locking device.....	21
3.3.3	Coupling type.....	21
3.3.4	Assembly of the coupling half.....	21
3.3.4.1	Balancing of coupling.....	21
3.3.4.2	Assembly.....	22
3.3.5	Belt drive.....	22

3.3.6	Drain plugs	22
3.4	Installation on concrete foundation	23
3.4.1	Scope of delivery	23
3.4.2	General preparations	23
3.4.3	Foundation preparations	23
3.4.3.1	Foundation and grouting hole preparations	23
3.4.3.2	Foundation studs or sole plate preparations	23
3.4.4	Erection of machines	25
3.4.5	Alignment	25
3.4.6	Grouting	25
3.4.7	Final installation and inspection	25
3.4.7.1	Dowelling of the machine feet	25
3.4.7.2	Covers and enclosures	26
3.5	Installation on steel foundation	26
3.5.1	Scope of delivery	26
3.5.2	Check of foundation	26
3.5.3	Erection of machines	26
3.5.4	Alignment	26
3.5.5	Final installation and inspection	26
3.5.5.1	Doweling of the machine feet	26
3.5.5.2	Covers and enclosures	27
3.5.6	Installation of flange mounted machines on steel foundation	27
3.6	Alignment	27
3.6.1	General	27
3.6.2	Rough levelling	28
3.6.3	Rough adjustment	28
3.6.4	Correction for thermal expansion	30
3.6.4.1	General	30
3.6.4.2	Thermal expansion upwards	30
3.6.4.3	Thermal axial growth	31
3.6.5	Final alignment	31
3.6.5.1	General	31
3.6.5.2	Run-out of the coupling halves	31
3.6.5.3	Parallel, angular and axial alignment	32
3.6.5.4	Alignment	33
3.6.5.5	Permissible misalignment	34
3.7	Care after installation	35

Chapter 4 - Mechanical and Electrical Connections

4.1	General	36
4.2	Mechanical connections	36
4.2.1	Cooling air connections	36
4.2.2	Cooling water connections	36
4.2.2.1	Air-to-water coolers	36
4.2.2.2	Water cooled frames	36
4.2.3	Sleeve bearing oil supply	37
4.2.4	Connection of purging air pipe	38
4.2.5	Mounting of vibration transducers	38
4.3	Electrical connections	38
4.3.1	General information	38

4.3.2	Safety	39
4.3.3	Insulation resistance measurements.....	39
4.3.4	Main terminal box options.....	40
4.3.4.1	Delivery without main terminal box	40
4.3.5	Insulation distances of main power connections	40
4.3.6	Main power cables	40
4.3.7	Secondary cables for slip ring connections.....	41
4.3.8	Auxiliary terminal box.....	41
4.3.8.1	Connection of auxiliaries and instruments.....	42
4.3.8.2	Connection of external blower motor	42
4.3.9	Earth connections.....	42
4.3.10	Requirements for machines fed by frequency converters.....	43
4.3.10.1	Main cable.....	43
4.3.10.2	Earthing of main cable	43
4.3.10.3	Auxiliary cables	43

Chapter 5 - Commissioning and Start-up

5.1	General.....	44
5.2	Check of mechanical installation.....	44
5.3	Insulation resistance measurements.....	44
5.4	Check of electrical installation	44
5.5	Control and protection equipment	45
5.5.1	General.....	45
5.5.2	Stator winding temperature.....	45
5.5.2.1	General	45
5.5.2.2	Resistance temperature detectors	46
5.5.2.3	Thermistors	46
5.5.3	Bearing temperature control	46
5.5.3.1	General	46
5.5.3.2	Resistance temperature detectors	46
5.5.3.3	Thermistors	46
5.5.4	Protection equipment	46
5.6	First test start.....	47
5.6.1	General.....	47
5.6.2	Precautions before first test start.....	47
5.6.3	Starting.....	48
5.6.3.1	Direction of rotation	48
5.6.3.2	Starting of machines with slip rings.....	48
5.6.3.3	Starting of Ex p machines	48
5.7	Running the machine the first time.....	49
5.7.1	Supervision during the first run	49
5.7.2	Checks during running of the machine	49
5.7.3	Bearings	49
5.7.3.1	Machines with rolling bearings.....	50
5.7.3.2	Machines with sleeve bearings	51
5.7.4	Vibrations.....	51
5.7.5	Temperature levels.....	51
5.7.6	Heat exchangers.....	52
5.7.7	Slip rings	52
5.8	Shut down	52

Chapter 6 - Operation

6.1	General	53
6.2	Normal operating conditions	53
6.3	Number of starts	53
6.4	Supervision	54
6.4.1	Bearings	54
6.4.2	Vibrations	54
6.4.3	Temperatures	54
6.4.4	Heat exchanger	55
6.4.5	Slip ring unit	55
6.5	Follow-up	55
6.6	Shut down	55

Chapter 7 - Maintenance

7.1	Preventive maintenance	56
7.2	Safety precautions	56
7.3	Maintenance program	57
7.3.1	Recommended maintenance program	59
7.3.1.1	General construction	60
7.3.1.2	Main supply connection	60
7.3.1.3	Stator and rotor	61
7.3.1.4	Auxiliaries	61
7.3.1.5	Slip ring unit	62
7.3.1.6	Lubrication system and bearings	62
7.3.1.7	Cooling system	63
7.4	Maintenance of general constructions	64
7.4.1	The tightness of fastenings	64
7.4.2	Vibration and noise	65
7.4.3	Vibrations	66
7.4.3.1	Measurement procedures and operational conditions	66
7.4.3.2	Classification according to support flexibility	67
7.4.3.3	Evaluation	67
7.5	Maintenance of bearings and lubrication system	68
7.5.1	Sleeve bearings	69
7.5.1.1	Oil level	69
7.5.1.2	Bearing temperature	69
7.5.2	Lubrication of sleeve bearings	69
7.5.2.1	Lubrication oil temperature	69
7.5.2.2	Control of the lubricant	70
7.5.2.3	Recommended control values for the lubricating oil	70
7.5.2.4	Oil qualities	70
7.5.2.5	Oil change schedule for mineral oils	71
7.5.3	Rolling bearings	72
7.5.3.1	Bearing construction	72
7.5.3.2	Bearing plate	72
7.5.3.3	Re-greasing intervals	72
7.5.3.4	Re-greasing	73
7.5.3.5	Bearing grease	74
7.5.3.6	Bearing maintenance	75

7.5.4	Bearing insulation and bearing insulation resistance check	75
7.5.4.1	Procedure	75
7.5.4.2	Cleanliness of bearing insulation	77
7.6	Maintenance of stator and rotor windings	78
7.6.1	Particular safety instructions for winding maintenance.....	78
7.6.2	The timing of the maintenance	79
7.6.3	The correct operating temperature.....	79
7.6.4	Insulation resistance test	79
7.6.4.1	Conversion of measured insulation resistance values.....	80
7.6.4.2	General considerations.....	81
7.6.4.3	Minimum values for insulation resistance	81
7.6.4.4	Stator winding insulation resistance measurement	82
7.6.4.5	Rotor winding insulation resistance measurement.....	83
7.6.5	Insulation resistance measurement for auxiliaries	84
7.6.6	The polarization index	84
7.6.7	Other maintenance operations	85
7.7	Maintenance of slip rings and brush gear	85
7.7.1	Care of slip rings.....	85
7.7.1.1	Standstill period	85
7.7.1.2	Wear	85
7.7.2	Care of brush gear.....	85
7.7.2.1	Brush pressure.....	86
7.8	Maintenance of cooling units.....	86
7.8.1	Maintenance instructions for machines with open air cooling	86
7.8.1.1	Cleaning of filters.....	87
7.8.2	Maintenance instructions for air-to-water heat exchangers	87
7.8.3	Maintenance instructions for air-to-air heat exchangers.....	87
7.8.3.1	Air circulation	87
7.8.3.2	Cleaning	88
7.8.4	Maintenance of external blower motors	88
7.9	Repairs, disassembly and assembly	89

Chapter 8 - Trouble Shooting

8.1	Trouble shooting	90
8.1.1	Mechanical performance.....	91
8.1.2	Lubrication system and bearings	92
8.1.2.1	Lubrication system and rolling bearings	92
8.1.2.2	Lubrication system and sleeve bearings.....	93
8.1.3	Thermal performance.....	95
8.1.3.1	Thermal performance, open air cooling system.....	95
8.1.3.2	Thermal performance, air-to-air cooling system.....	96
8.1.3.3	Thermal performance, air-to-water cooling system	97
8.1.3.4	Thermal performance, rib cooled.....	98
8.2	Oil leakage of sleeve bearings	99
8.2.1	Oil	99
8.2.2	Sleeve bearings	100
8.2.3	Bearing verification	100
8.2.4	Oil container and piping	101
8.2.5	Oil container and piping verification	101
8.2.6	Use	102

8.2.7	Use verification	103
8.3	Electrical performance, excitation, control and protection	106
8.3.1	Protection trips	106
8.3.2	Pt-100 resistance temperature detectors.....	106
8.4	Slip rings and brushes	108
8.4.1	Brush wear	108
8.4.2	Brush sparking	108
8.5	Thermal performance and cooling system	109

Chapter 9 - After Sales Support and Spare Parts

9.1	After Sales.....	110
9.1.1	Site Services.....	110
9.1.2	Spare Parts.....	110
9.1.3	Support and Warranties.....	110
9.1.4	Support for Service Centers	110
9.1.5	After Sales contact information	110
9.2	Spare parts for rotating electrical machines	111
9.2.1	General spare part considerations	111
9.2.2	Periodical part replacements	111
9.2.3	Need of spare parts.....	111
9.2.4	Selection of the most suitable spare part package.....	112
9.2.5	Typical recommended spare parts in different sets.....	112
9.2.5.1	Operational spare part package	112
9.2.5.2	Recommended spare part package	113
9.2.5.3	Capital spare parts	113
9.2.5.4	Operational spare part package	113
9.2.5.5	Recommended spare part package	114
9.2.5.6	Capital spare parts	114
9.2.5.7	Operational spare part package	115
9.2.5.8	Recommended spare part package	116
9.2.5.9	Capital spare parts	116
9.2.6	Order information.....	116

Chapter 10 - Recycling

10.1	Introduction	117
10.2	Average material content	117
10.3	Recycling of packaging material.....	117
10.4	Dismantling of the machine	118
10.5	Separation of different materials.....	118
10.5.1	Frame, bearing housing, covers and fan.....	118
10.5.2	Components with electrical insulation	118
10.5.3	Permanent magnets	119
10.5.4	Hazardous waste.....	119
10.5.5	Land fill waste.....	119
	COMMISSIONING REPORT	120
	Typical position of plates	130
	Typical main power cable connections	131

Chapter 1 Introduction

1.1 General information

This User's Manual contains information on the transport, storage, installation, commissioning, operating and maintenance of rotating electrical machines manufactured by ABB.

This manual provides information regarding all aspects of operation, maintenance and supervision of the machine. Careful study of the contents of this manual and other machine related documentation before any actions are taken is necessary to ensure proper functionality and a long lifetime of the machine.

NOTE: Some customer specific items may not be included in this User's Manual. Additional documentation will be found in the project documentation.

Actions described in this manual are only to be performed by trained personnel with previous experience in similar tasks, and authorized by the user.

This document and parts thereof must not be reproduced or copied without the express written permission of ABB, and the contents thereof must not be imparted to a third party nor be used for any unauthorized purpose.

ABB constantly strives to improve the quality of the information provided in this User's Manual, and will welcome any improvement suggestions. For contact information, see *Chapter 9.1.5 After Sales contact information*.

NOTE: These instructions must be followed to ensure safe and proper installation, operation and maintenance of the machine. They should be brought to the attention of anyone who installs, operates or maintains this equipment. Ignoring the instruction invalidates the warranty.

1.2 Important note

The information in this document may sometimes be of a general nature and applicable to various machines produced by ABB.

Where a conflict exists between the contents herein and the actual machinery supplied, the user must make an engineering judgment as to what to do. If any doubt exists, contact ABB.

The safety precautions presented in the *Safety Instructions* at the beginning of the manual must be observed at all times.

Safety is dependent on the awareness, concern and prudence of all those who operate and service machines. While it is important that all safety procedures be observed, care near machinery is essential - always be on your guard.

NOTE: To avoid accidents, safety measures and devices required at the installation site must be in accordance with the instructions and regulations stipulated for safety at work. This applies to general safety regulations of the country in question, specific agreements made for each work site and safety instructions included in this manual and separate safety instructions delivered with the machine.

1.3 Limitation of liability

In no event shall ABB be liable for direct, indirect, special, incidental or consequential damages of any nature or kind arising from the use of this document, nor shall ABB be liable for incidental or consequential damages arising from use of any software or hardware described in this document.

The warranty issued covers manufacturing and material defects. The warranty does not cover any damage caused to the machine, personal or third party by improper storage, incorrect installation or operating of the machine. The warranty conditions are in more detail defined according to Orgalime S2000 terms and conditions.

NOTE: The warranty issued is not valid, if the operation conditions of the machine are changed or any changes in the construction of the machine, or repair work to the machine have been made without prior written approval from the ABB factory, which supplied the machine.

NOTE: Local ABB sales offices may hold different warranty details, which are specified in the sales terms, conditions or warranty terms.

For contact information, please see the back page of this User's Manual. Please remember to provide the serial number of the machine when discussing machine specific issues.

1.4 Documentation

1.4.1 Documentation of the machine

It is recommended that the documentation of the machines is studied carefully before any actions are taken. This manual and safety instructions are delivered with each machine and is located in a plastic cover attached on the machine frame.

NOTE: The documentation is delivered to the ordering customer. For additional copies of these documents, please contact your local ABB office or the After Sales department, see *Chapter 9.1.5 After Sales contact information*.

In addition to this manual, each machine is supplied with a Dimension Drawing, an Electrical Connection Diagram and a Data Sheet indicating the following:

- Mounting and outline dimensions of the machine
- Machine weight and load on the foundation
- Location of lifting eyes of the machine
- Instrumentation and location of accessories
- Bearing oil and lubricant requirements
- Main and auxiliary connections.

NOTE: Some customer specific items may not be included in this User's Manual. Additional documentation will be found in the project documentation. In case of conflict between this manual and the additional documentation of the machine, additional documentation will prevail.

1.4.2 Information not included in documentation

This User's Manual does not include any information about any starting, protection or speed control equipment. This information is provided in the user's manuals for respective equipment.

1.4.3 Units used in this User's Manual

The measurement units used in this User's Manual are based on the SI (metric) system and the US system.

1.5 Identification of the machine

1.5.1 Serial number of the machine

Each machine is identified with a 7-digit serial number. It is stamped on the rating plate of the machine as well as on the machine frame.

The serial number must be provided in any future correspondence regarding a machine, as it is the only unique information used for identifying the machine in question.

1.5.2 Rating plate

A stainless steel rating plate is attached permanently to the machine frame, and it must not be removed. For the location of the rating plate, see *Appendix Typical position of plates*.

The rating plate indicates manufacturing, identification, electrical and mechanical information, see *Figure 1-1 Rating plate for direct on line machines manufactured according to IEC (Ex-machine according to ATEX Directive)*.

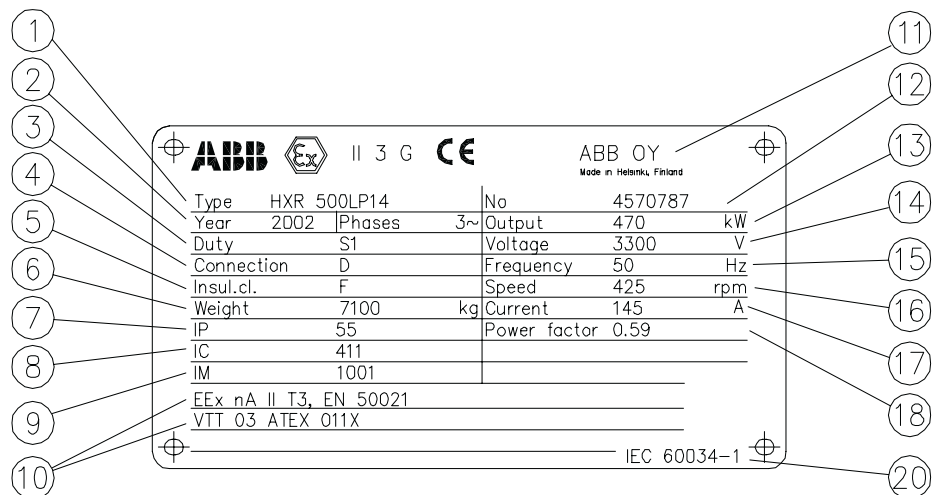

Figure 1-1 Rating plate for direct on line machines manufactured according to IEC (Ex-machine according to ATEX Directive)

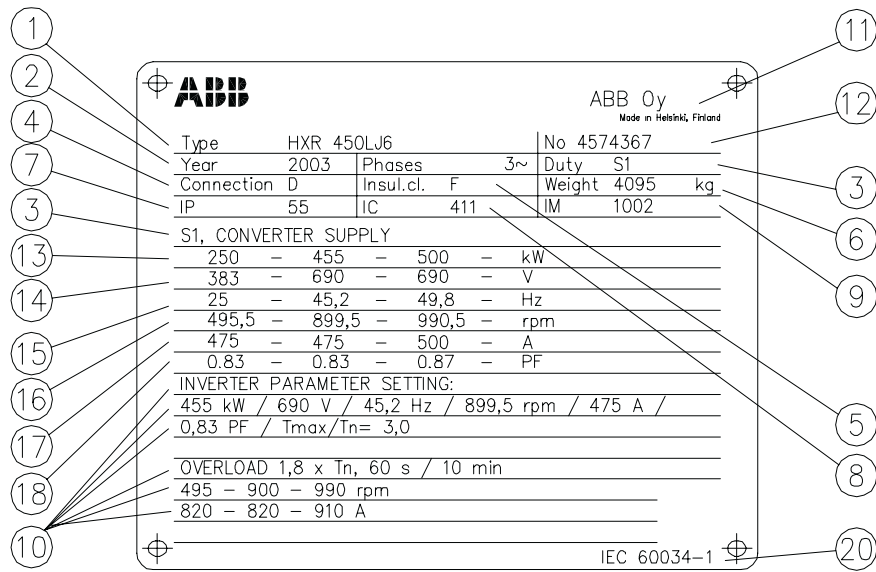

Figure 1-2 Rating plate for frequency converter machines manufactured according to IEC

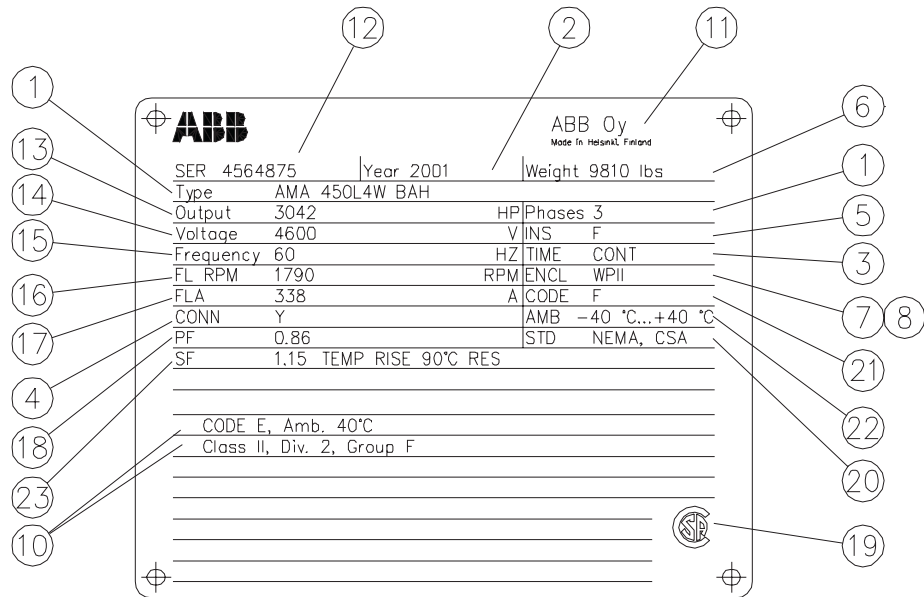

Figure 1-3 Rating plate for direct on line machines manufactured according to NEMA

1. Type designation
2. Manufacturing year
3. Duty
4. Type of connection
5. Insulation class
6. Machine weight [kg] or [lbs]
7. Degree of protection [IP class]
8. Type of cooling [IC code]

9. Mounting arrangement [IM code] (IEC)
10. Additional info
11. Manufacturer
12. Serial number
13. Output [kW] or [HP]
14. Stator voltage [V]
15. Frequency [Hz]
16. Rotating speed [rpm]
17. Stator current [A]
18. Power factor [cos ϕ]
19. CSA marking
20. Standard
21. Designation for locked-rotor kVA/ HP (NEMA)
22. Ambient temperature [$^{\circ}$ C] (NEMA)
23. Service factor (NEMA)

Chapter 2 Transport and Unpacking

2.1 Protective measures prior to transport

2.1.1 General

The following protective measures are taken before delivery of the machine from the factory. The same protective measures should be taken, whenever the machine is moved:

- Some machines, and all machines with sleeve or roller bearings, have transport locking devices installed

*****Following bullet for bearing type: Rolling bearing**

- Ball and roller bearings are greased with lubricant indicated on the bearing plate, which is attached to the machine frame, see *Chapter 2.1.2 Bearing plate*

*****Following bullet for bearing type: Sleeve bearing**

- Sleeve bearings are flooded with oil and drained. All oil in- and outlets, as well as oil tubes are plugged. This gives sufficient protection against corrosion

*****Following bullet for cooling method: Air-to-water**

- Air-to-water coolers are drained and the cooler in- and outlets are plugged
- Machined metal surfaces, such as the shaft extension, are protected against corrosion with an anti-corrosive coating
- In order to protect the machine properly against water, salt spray, moisture, rust and vibration damages during loading, sea transport and unloading of the machine, the machine should be delivered in a seaworthy package.

2.1.2 Bearing plate

A stainless steel bearing plate is attached to the machine frame. For the location of the bearing plate, see *Appendix Typical position of plates*.

The bearing plate indicates the type of the bearings and lubrication to be used, see *Figure 2-1 Bearing plate for grease lubricated rolling bearings* and *Figure 2-2 Bearing plate for sleeve bearings*.

*****Following figure for bearing type: Rolling bearing**

DRIVE END (DE) BEARING	6326/C3	1
NON DRIVE END (NDE) BEARING	6324/C3	2
LUBRICATION INTERVAL AT 70°C (158°F) BEARING TEMPERATURE	8800 DUTY HOURS	3
QUANTITY OF GREASE DE	80 GRAMS	4
NDE	80 GRAMS	5
NOTE! EVERY 15°C (59°F) INCREASE ABOVE 70°C (158°F) IN THE BEARING TEMPERATURE HALVES THE RATED LUBRICATION INTERVAL.		6
NOTE! ABOVE 85°C (185°F) HIGH TEMPERATURE GREASE SHALL BE USED.		6
Empty the waste grease box every 6th relubrication		7
DELIVERED FROM FACTORY WITH GREASE	ESSO UNIREX N2	7
FOR ADDITIONAL INFORMATION SEE MAINTENANCE MANUAL		

Figure 2-1 Bearing plate for grease lubricated rolling bearings

1. Bearing type of D-end
2. Bearing type of ND-end
3. Lubrication interval
4. Quantity of grease for D-end bearing
5. Quantity of grease for ND-end bearing
6. Additional information
7. Type of grease delivered from factory

*****Following figure for bearing type: Sleeve bearing**

DRIVE END (DE) BEARING	EFZLK 11-125	1
NON DRIVE END (NDE) BEARING	EFZLQ 11-125 (INSULATED)	2
OIL CHANGE EVERY	8800 DUTY HOURS	4
VISCOSITY	ISO VG 46	4
OIL QUANTITY DE BEARING	4.2 l	5
OIL QUANTITY NDE BEARING	4.2 l	6
DE BEARING LUBRICATION	SELF LUBRICATION BY OIL RING	7
NDE BEARING LUBRICATION	SELF LUBRICATION BY OIL RING	7
ROTOR END FLOAT	+/- 8 mm	8
FOR ADDITIONAL INFORMATION SEE MAINTENANCE MANUAL		9

Figure 2-2 Bearing plate for sleeve bearings

1. Bearing type for D-end
2. Bearing type for ND-end
3. Oil change interval
4. Viscosity class
5. Oil quantity for D-end bearing (for self lubricated)
6. Oil quantity for ND-end bearing (for self lubricated)
7. Method of lubrication for D-end bearing. Oil flow and pressure for flood lubricated bearing
8. Method of lubrication for ND-end bearing. Oil flow and pressure for flood lubricated bearing
9. Rotor end float (axial play)

NOTE: The information given on the bearing plate must imperatively be followed. Failure to do so will void the warranty for the bearings.

2.2 Lifting the machine

Before the machine is lifted, ensure that suitable lifting equipment is available and that the personnel is familiar with lifting work. The weight of the machine is shown on the rating plate, dimension drawing and packing list.

NOTE: Use only the lifting lugs or eyes intended for lifting the complete machine. Do not use any small additional lifting lugs or eyes available, as they are there only for service purposes.

NOTE: The center of gravity of machines with the same frame may vary due to different outputs, mounting arrangements and auxiliary equipment.

NOTE: Check that eyebolts or the lifting lugs integrated with the machine frame are undamaged before lifting. Damaged lifting lugs must not be used.

NOTE: Lifting eyebolts must be tightened before lifting. If needed the position of the eyebolt must be adjusted with suitable washers.

2.2.1 Lifting a machine in a seaworthy package

The seaworthy package is normally a wooden box, which is covered with lamina paper on the inside. The seaworthy package should be lifted by forklift from the bottom, or by crane with lifting slings. The sling positions are painted on the package.

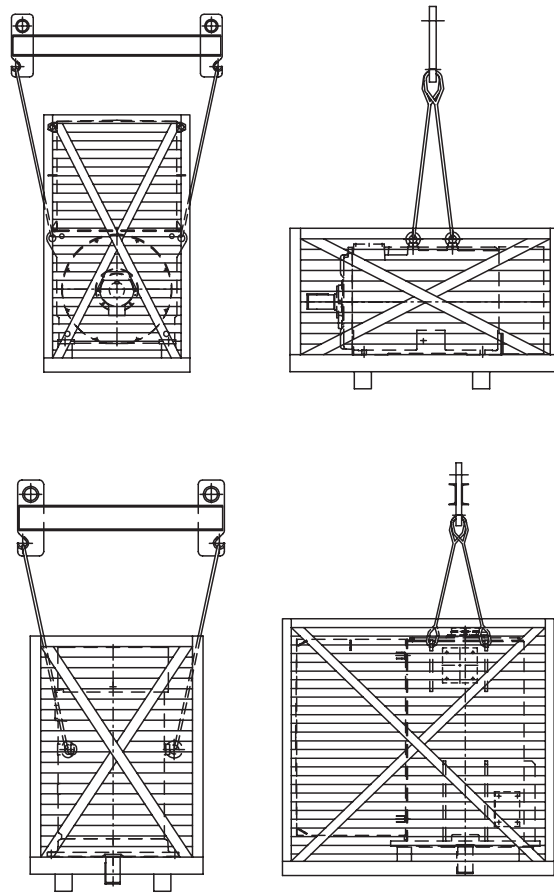

Figure 2-3 Lifting of horizontal and vertical machines in seaworthy packages

2.2.2 Lifting a machine on a pallet

A machine mounted on a pallet should be lifted by crane from the lifting eyes of the machine, see *Figure 2-4 Lifting of horizontal and vertical machines on pallets*, or by forklift from the bottom of the pallet. The machine is fixed to the pallet with bolts.

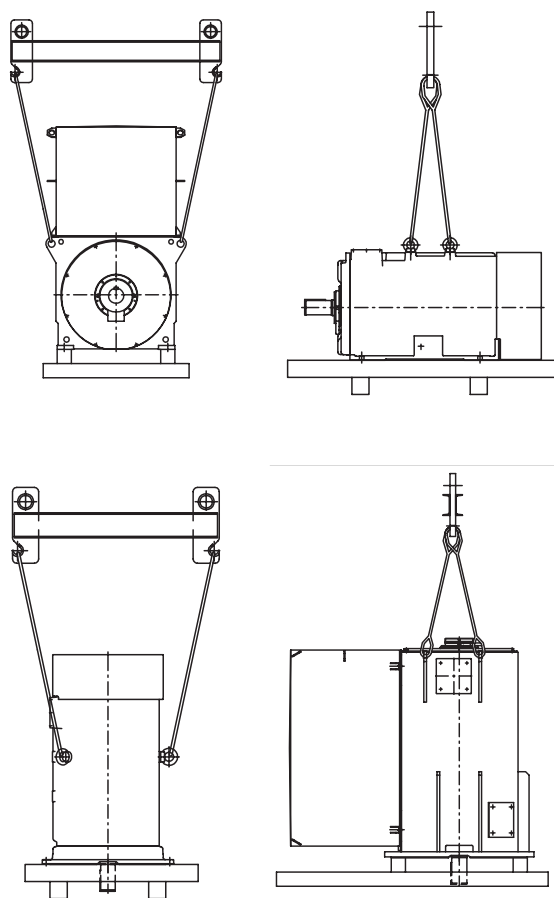

Figure 2-4 Lifting of horizontal and vertical machines on pallets

2.2.3 Lifting an unpacked machine

Suitable lifting equipment must be used! The machine should always be lifted by crane from the lifting eyes on the frame of the machine, see *Figure 2-5 Lifting of unpacked machines*. The machine should *never* be lifted by forklift from the bottom or the feet of the machine.

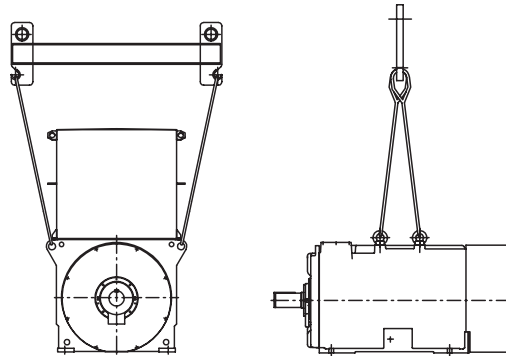

Figure 2-5 Lifting of unpacked machines

***Following chapter for mounting type: Vertical

2.3 Turning a vertically mounted machine

Vertically mounted machines may be necessary to turn from vertical to horizontal position, e.g. when changing the bearings, and vice versa. This is shown in *Figure 2-6 Machine with turnable lifting eyes: lifting and turning*. Avoid damaging the painting or any parts during the procedure. Remove or install the bearing locking device only when the machine is in vertical position.

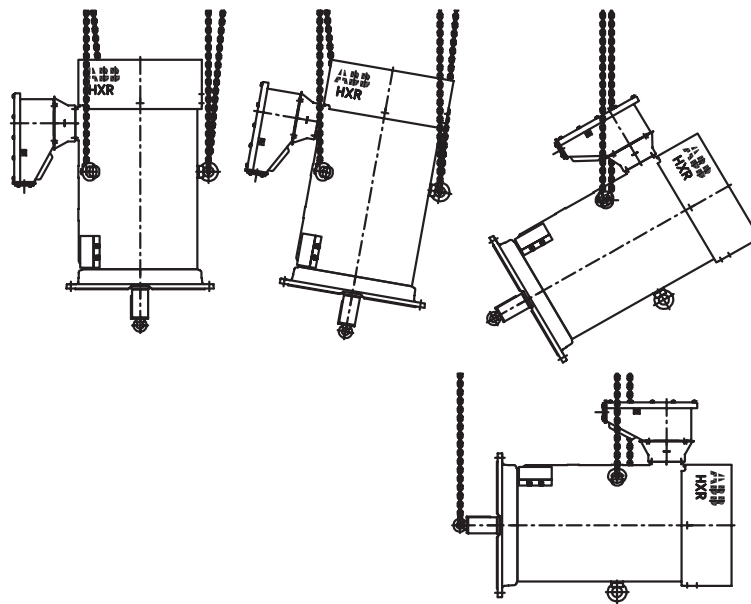

Figure 2-6 Machine with turnable lifting eyes: lifting and turning

2.4 Checks upon arrival and unpacking

2.4.1 Check upon arrival

The machine and the package must be inspected immediately upon arrival. Any transport damage must be photographed and reported immediately, i.e. within less than one (1) week after arrival, if the transport insurance is to be claimed. It is, therefore, important that evidence of careless handling is checked and reported immediately to the transport company and the supplier. Use checklists in *Appendix COMMISSIONING REPORT*.

A machine, which is not to be installed immediately upon arrival, must not be left without supervision or without protective precautions. For more details, see *Chapter 2.6 Storage*.

2.4.2 Check upon unpacking

Place the machine so that it does not hinder the handling of any other goods and on a flat, vibration-free surface.

After the package has been removed, check that the machine is not damaged and that all accessories are included. Tick off the accessories on the packing list which is enclosed. If there is any suspected damage or if accessories are missing, take photographs thereof and report this immediately to the supplier. Use checklists in *Appendix COMMISSIONING REPORT*.

For correct recycling and disposal of the packaging material, see *Chapter 10.3 Recycling of packaging material*.

2.5 Installation instructions for main terminal box and cooler parts

These instructions are applied, when the machine is delivered on site with disassembled main components, such as the main terminal box or cooler parts. Refer to the Dimension Drawing included in the project documentation for the correct positions of the parts. All bolts, nuts and washers are included in the delivery.

Mechanical assembly should be done only by experienced personnel. Electrically active parts such as stator cables should be installed by skilled persons only.

Safety instructions must be observed at all times, for more information see *Safety Instructions* at the beginning of the manual.

To ensure that the warranty terms agreed in the purchase order contract of the project are not invalidated, these instructions should be followed carefully.

2.5.1 Installation of main terminal box

The main terminal box is delivered with the machine in a separate box/slide package. The installation of the main terminal box is performed according to these guidelines.

1. Open the package and lift the main terminal box with a suitable lifting device (for example a crane) from the lifting eyes of the main terminal box.
2. Check that all connection parts are free of dust and dirt.
3. Prepare the delivered bolts and washers for installation.

4. Lift the main terminal box directly onto the machine frame at the position where the main terminal box has to be connected (see Dimension Drawing included in the project documentation).
5. For NEMA main terminal box only: pull the stator cables through the ceiling membrane.
6. Connect the main terminal box with the screws delivered with the machine frame. Make sure that the isolation sealing is available to the connection surface of the machine housing.
7. Tighten all screws with max. 200 Nm. (see *Table 7-2 General tightening torques*).

For NEMA main terminal box only: After connecting the main terminal box mechanically to the machine housing, the stator cables are connected to the terminals:

1. Check the markings of the stator cables and the terminals.
2. Connect the stator cables to the corresponding terminals according to the cable markings (U1, V1, W1 or L1, L2, L3). See the Electrical Connection Diagram for more information.
3. Tighten the preinstalled screws with max. 80 Nm. (see *Appendix Typical main power cable connections*).

2.5.2 Installation of cooler parts

If the cooler or parts of the cooling system (for example silencer, air lead channel) are delivered separately, they have to be installed on site according to the following instructions.

1. Open the package of the cooler/cooler parts and lift the part(s) using a suitable lifting device (for example a crane) from the lifting eyes of the package.
2. Check that all connection parts are free of dust and dirt.
3. Check the correct installation positions from the Dimension Drawing delivered with the project documentation.
4. Check that all connection parts, bolts, washers and nuts are included in the delivery.
5. Lift the cooler part to its correct position and connect it with the delivered installation parts. Make sure that all sealing parts are installed at correct locations.
6. Tighten all screws with max. 80 Nm. (see *Table 7-2 General tightening torques*).

2.6 Storage

2.6.1 Short term storage (less than 2 months)

The machine should be stored in a proper warehouse with a controllable environment. A good warehouse or storage place has:

- A stable temperature, preferably in the range from 10°C (50°F) to 50°C (120°F). If the anti-condensation heaters are energized, and the surrounding air is above 50°C (120°F), it must be confirmed that the machine is not overheated
- Low relative air humidity, preferably below 75%. The temperature of the machine should be kept above the dew point, as to prevent moisture from condensing inside the machine. If the machine is equipped with anti-condensation heaters, they should be energized. The operation of the anti-condensation heaters must be verified periodically. If the machine is not equipped with anti-condensation heaters, an alternative method of heating the machine

and preventing moisture from condensing in the machine must be used

- A stable support free from excessive vibrations and shocks. If vibrations are suspected to be too high, the machine should be isolated by placing suitable rubber blocks under the machine feet
- Air which is ventilated, clean and a free from dust and corrosive gases
- Protection against harmful insects and vermin.

If the machine needs to be stored outdoors, the machine must never be left 'as is' in its transportation package. Instead the machine must be

- Taken out from its plastic wrap
- Covered, as to completely prevent rain from entering the machine. The cover should allow ventilation of the machine
- Placed on at least 100 mm (4") high rigid supports, as to make sure that no moisture can enter the machine from below
- Provided with good ventilation. If the machine is left in its transportation package, large enough ventilation openings must be made in the package
- Protected from harmful insects and vermin.

Use checklists in Chapter 2 Storage in *Appendix COMMISSIONING REPORT*.

2.6.2 Long term storage (more than 2 months)

In addition to the measures described with short-term storage, the following should be applied.

Measure the insulation resistance and temperature of the windings every three months, see *Chapter 7.6 Maintenance of stator and rotor windings*.

Check the condition of the painted surfaces every three months. If corrosion is observed, remove it and apply a coat of paint again

Check the condition of anti-corrosive coating on blank metal surfaces (e.g. shaft extensions) every three months. If any corrosion is observed, remove it with a fine emery cloth and perform the anti-corrosive treatment again

Arrange small ventilation openings when the machine is stored in a wooden box. Prohibit water, insects and vermin from entering the box, see *Figure 2-7 Ventilation holes*.

Use checklists in Chapter 2 Storage in *Appendix COMMISSIONING REPORT*.

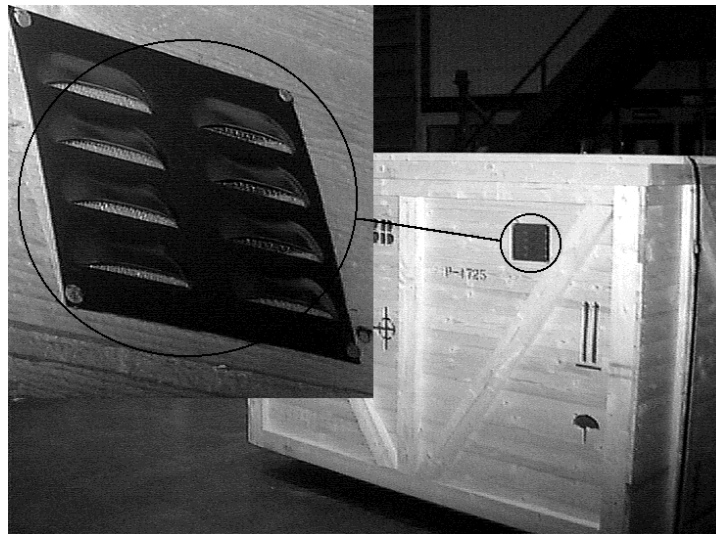

Figure 2-7 Ventilation holes

*****Following paragraph for cooling method: Water jacket**

Machines with so-called water jacket cooling are to be filled with a mixture of water and glycol with a minimum of 50% glycol. Instead of glycol, another similar liquid can be accepted. Make sure that the liquid mixture tolerates the storage temperature without freezing. The liquid inlets and outlets are to be closed after filling.

*****Following chapter for bearing type: Rolling bearing**

2.6.3 Rolling bearings

Apply the following measures:

- Rolling bearings should be well lubricated during storage. Acceptable grease types are presented in *Chapter 2.1.2 Bearing plate*
- Turn the rotor 10 revolutions every three months to keep the bearings in good condition. Remove any possible transport locking device during turning the rotor
- Machines may be provided with a locking device to protect the bearings against damage during transport and storage. Check the bearing locking device periodically. Tighten the transport locking device according to the axially locating bearing type, see *Table 2-1 Tightening torque for horizontal machines (lubricated screw)*.

NOTE: A too high tightening torque on the transport locking device will damage the bearing.

NOTE: The type of bearings used are found on the bearing plate, see *Chapter 2.1.2 Bearing plate*, and axially locating bearing information from the dimension drawing.

*****Following table for mounting type: Horizontal**

Table 2-1. Tightening torque for horizontal machines (lubricated screw)

Axially locating bearing type	Tightening torque [Nm]	Tightening torque [pound foot]
6316	45	33
6317	50	37
6319	60	44
6322	120	90
6324	140	100
6326	160	120
6330	240	180
6334	300	220
6034	140	100
6038	160	120
6044	230	170

*****Following table for mounting type: Vertical****Table 2-2. Tightening torque for vertical machines (lubricated screw)**

Axially locating bearing type	Tightening torque [Nm]	Tightening torque [pound foot]
7317	30	22
7319	30	22
7322	60	44
7324	60	44
7326	90	66
7330	160	120
7334	350	260

*****Following chapter for bearing type: Sleeve bearing****2.6.4 Sleeve bearings**

Apply the following measures:

- Machines with sleeve bearings are delivered *without lubricant*, i.e. oil. The inside of the bearings should be checked for a protective oil layer. Tectyl 511 or other corresponding substance should be sprayed into the bearing through the filling hole, if the storing period is longer than two months. The corrosion protection treatment is repeated every six months for a period of two years. If the storing period is longer than two years, the bearing has to be taken apart and treated separately
- The bearings should be opened, and all parts inspected after storage and before commissioning. Any corrosion must be removed with a fine emery cloth. If the shaft has left imprints on the lower liner-half, it must be replaced with a new one
- Machines with sleeve bearings are provided with a transport locking device to protect the bearings against damage during transport and storage. Check the transport locking device periodically. Tighten the transport locking device according to the axially locating bearing, see *Table 2-1 Tightening torque for horizontal machines (lubricated screw)*.

NOTE: A too high tightening torque on the transport locking device will damage the bearing.

Table 2-3. Tightening torque (lubricated screw). Axially locating bearing carries the locking force

Axially locating bearing type	Tightening torque [Nm]	Tightening torque [pound foot]
ZM_LB 7	100	74
EF_LB 9	250	180
EF_LB 11	300	220
EF_LB 14	600	440
EM_LB 14	600	440
EF_LB 18	900	670

2.6.5 Openings

If there are any openings where cables are not connected to terminal boxes or flanges that are not connected to the piping, they are to be sealed. The coolers and the piping within the machine are to be cleaned and dried before they are sealed. The drying is made by blowing warm and dry air through the pipes.

2.7 Inspections, records

The storage period, taken precautions and measurements, including dates, should be recorded. For relevant check-lists, see *Appendix COMMISSIONING REPORT*.

Chapter 3 Installation and Alignment

3.1 General

Good planning and preparation result in simple and correct installation and assure safe running conditions and maximum accessibility.

*****Following paragraph for protection type: All machines for hazardous areas**

Standards relating to the connection and use of electrical apparatus in hazardous areas must be taken into consideration, especially national standards for installation (see standard IEC 60079-14).

NOTE: General, as well as local work safety instructions must be followed during installation.

NOTE: Ensure the protection of the machine while working nearby.

NOTE: Do not use the machine as a welding earth.

3.2 Foundation design

3.2.1 General

The design of the foundation should assure safe running conditions with maximum accessibility. Sufficient free space should be left around the machine to ensure easy access for maintenance and monitoring. The cooling air should flow to and away from the machine without obstruction. Care has to be taken to ensure that other machines or equipment nearby do not heat the machine cooling air or constructions such as bearings.

The foundation must be strong, rigid, flat and free from external vibration. The possibility of machine resonance with the foundation has to be verified. In order to avoid resonance vibrations with the machine, the natural frequency of the foundation together with machine must not be within a $\pm 20\%$ range of the running speed frequency.

A concrete foundation is preferred, however, a correctly designed steel construction is also acceptable. The anchorage to the foundation, the provision of air, water, oil and cable channels as well as the location of the grouting holes should be considered prior to construction. The position of the grouting holes and the height of the foundation must agree with the corresponding dimensions on the provided dimensional drawing.

The foundation shall be designed to permit 2 mm (0.8 inch) shim plates under the feet of the machine in order to ensure an adjustment margin, and facilitate the possible future installation of a replacement machine. Machine shaft height and foundation feet location have a certain manufacturing tolerance, which are compensated with the 2 mm (0.8 inch) shim plate.

NOTE: The calculation and design of the foundation is not included in the ABB scope of supply and the customer or a third party is therefore responsible for it. Furthermore, the grouting operation is also normally outside the scope and responsibility of ABB.

3.2.2 Forces to the foundation

The foundation and the mounting bolts must be dimensioned to withstand a sudden mechanical torque, which occurs every time the machine is started, or at short circuit. The short circuit force is a gradually damped sine wave that changes direction. The magnitude of these forces is mentioned on the dimensional drawing of the machine.

*****Following chapter for mounting type: Vertical**

3.2.3 Flanges for vertically mounted machines

Vertical flange mounted machines are equipped with a mounting flange according to IEC-standard publication 60072. The flange of the machine should always be mounted to an opposite flange on the foundation.

A mounting adapter is recommended to enable an easy coupling connection and inspection during operation.

3.3 Machine preparations before installation

Prepare the machine for installation as follows:

- Measure the insulation resistance of the winding before any other preparations are done as described in *Chapter 3.3.1 Insulation resistance measurements*
- Remove the transport locking device when applicable. Store it for future use. See *Chapter 3.3.2 Disassembly of the transport locking device* for further instructions
- Verify that the grease available is according to the specification on the bearing plate, see *Chapter 2.1.2 Bearing plate*. Additional recommended greases can be found in *Chapter 7.5.3.5 Bearing grease*

*****Following bullet and note for bearing type: Sleeve bearing**

- Fill the sleeve bearings with an appropriate oil. For suitable oils, see *Chapter 7.5.2.4 Oil qualities*

NOTE: Sleeve bearings are always delivered without oil!

- Remove the anti-corrosive coating on the shaft extension, and machine feet with white spirit
- Install the coupling half as described in *Chapter 3.3.4 Assembly of the coupling half*
- Check that the drain plugs at the lowest part of both ends of the machine are in open position, see *Chapter 3.3.6 Drain plugs*.

3.3.1 Insulation resistance measurements

Before a machine is started up for the first time, after a long period of standstill or within the scope of general maintenance work, the insulation resistance of the machine must be measured. This includes measuring the stator winding and all auxiliary devices. For machines equipped with slip ring, the measuring also includes the rotor winding, see *Chapter 7.6.4 Insulation resistance test*.

3.3.2 Disassembly of the transport locking device

Some machines and all machines with sleeve or roller bearings have transport locking devices installed. For machines with sleeve or cylindrical roller bearings, the transport locking device is made of a steel bar attached to both the bearing shield on the D-end and to the end of the shaft extension.

The transport locking device has to be removed prior to installation. The shaft extension has to be cleaned of its anti-corrosive coating. The locking device should be stored for future use.

NOTE: In order to avoid bearing damages, the transport locking device must be fitted to the machine whenever the machine is moved, transported to another location or stored. See *Chapter 2.1 Protective measures prior to transport*.

3.3.3 Coupling type

*****Following paragraph for bearing type: Rolling bearing**

Machines with rolling bearings must be connected to the driven machine with flexible couplings, e.g. pin couplings, or gear couplings.

If the axially locked bearing is at the N-end (see dimension drawing), make sure that a continuous free axial movement is possible between the coupling halves in order to permit thermal expansion of the machine shaft without damaging the bearings. The expected axial thermal expansion of the rotor can be calculated as defined in the *Chapter 3.6.4 Correction for thermal expansion*.

*****Following paragraph for mounting type: Vertical**

Vertical machines may be designed to carry some load from the shaft of the driven machine. If this is the case, the coupling halves have to be locked against slipping in the axial direction by a lock plate on the end of the shaft.

NOTE: The machine is not suitable for belt, chain or gear connection unless it is specifically designed for such use. The same applies for high axial thrust applications.

*****Following two paragraphs and figure for bearing type: Sleeve bearing with axial float**

The sleeve bearing construction allows the rotor to move axially between the mechanical end float limits. Standard bearings cannot withstand any axial forces from the driven machine. Any axial force from the load will cause bearing damage. Therefore, all axial forces must be carried by the driven machine and the coupling must be of limited axial float type.

3.3.4 Assembly of the coupling half

3.3.4.1 Balancing of coupling

The rotor is dynamically balanced with half key as standard. The way of balancing is stamped to the shaft end:

- H = half-key and
- F = full key

The coupling half must be balanced respectively.

3.3.4.2 Assembly

The following instructions must be taken into account when assembling the coupling half.

- Follow the general instructions of the coupling supplier
- The weight of the coupling half can be considerable. A suitable lifting gear may be needed
- Clean the shaft extension of its anti-corrosive coating, and check the measurements of the extension and the coupling against the provided drawings. Ensure also that the keyways in the coupling and the shaft extension are clean and free from burrs
- Coat the shaft extension and hub bore with a thin layer of oil as to facilitate the mounting of the coupling half. Never coat mating surfaces with molybdenum disulphide (Molykote) or similar products
- The coupling must be covered with a touch guard.

NOTE: In order not to damage the bearings, no additional forces should be applied to the bearings when assembling the coupling half.

3.3.5 Belt drive

Machines designed for belt drives are always equipped with cylindrical roller bearing in the D-end. If a belt drive is used, make sure that the driving and the driven pulleys are correctly aligned.

NOTE: Suitability of the shaft end and the bearings for the belt drive must be always checked before use. Do not exceed the radial force specified in the order definitions.

3.3.6 Drain plugs

The machines are equipped with drain plugs in the lowest part of the machine. The drain plug is constructed in such a way that it keeps the dust outside the machine and lets the condensation water to drain out. The drain plugs should always be open, i.e. half of the plug is inside and half of the plug is outside. The drain plug is opened by pulling it out from the frame. In AMI machines the drain plug (M12 screw) is opened 6 - 12 mm (0.2" - 0.5").

*****Following paragraph for mounting type: Horizontal**

For horizontal machines, two drain plugs are fitted at both ends of the machine.

*****Following paragraph for mounting type: Vertical**

For vertical machines, two drain plugs are fitted to the lower end shield.

The main terminal box has one drain plug at the lowest part of the box which has to be closed during operation.

*****Following chapter for mounting type: Horizontal with concrete foundation**

3.4 Installation on concrete foundation

3.4.1 Scope of delivery

The machine delivery does not normally include installation, shim plates, mounting bolts, foundation plate set or sole plate set. These are delivered according to special orders.

If new fixing holes need to be drilled, please contact ABB to ensure suitability.

3.4.2 General preparations

Before starting the installation procedure, consider the following aspects:

- Reserve sheet steel material for shimming the machine. Possible alignment adjustments require shims with thicknesses of 1, 0.5, 0.2, 0.1 and 0.05 mm (40, 20, 8, 4 and 2 mil)
- Reserve a recoil hammer, adjusting screws or hydraulic jacks for axial and horizontal adjustments
- Reserve dial indicator gauges, or preferably a laser optical analyzer, to achieve accurate and precise alignment of the machine
- Reserve a simple lever arm for turning the rotor during alignment
- With outdoor installations provide sun and rain protection to eliminate measuring errors during installation.

NOTE: Machines are delivered with jacking screws for vertical adjustment at each foot.

3.4.3 Foundation preparations

3.4.3.1 Foundation and grouting hole preparations

Foundation studs or sole plates are used when the machine is anchored to a concrete foundation.

Consider the following aspects when preparing the foundation:

- The upper part of the foundation has to be swept or vacuum cleaned
- Walls of the grouting holes must have rough surfaces to give a good grip. For the same reason they must be washed and rinsed and thus free from pollution and dust. Oil or grease must be removed by chipping away slices of the concrete surfaces
- Check that the position of the grouting holes and the height of the foundation agree with corresponding measurements on the drawing provided
- Attach a steel wire on the foundation to indicate the center line of the machine. Mark also the axial position of the machine.

3.4.3.2 Foundation studs or sole plate preparations

If shims and foundation studs are part of the delivery, they will be delivered as separate items. The assembly of these will be made at site.

NOTE: To ensure that the foundation studs will be satisfactorily attached to the concrete, they must be unpainted and free from pollution and dust.

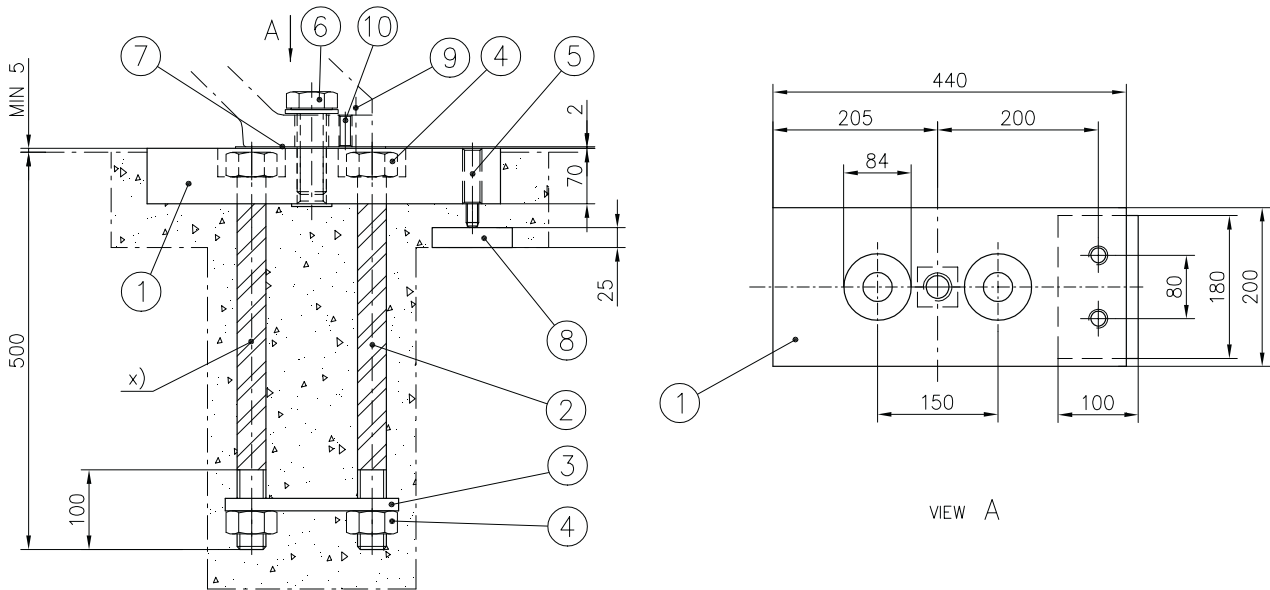

ITEM	NAME OF THE PARTS	SIZE	QUANTITY/SET [PCS]
1	PLATE	70x200x440	4
2	STUD	M36x500/45+100	8
3	FLANGE	10x60x210	4
4	NUT	M36	16
5	JACKING SCREW	M24x60	8
6	FIXING SCREW	M36x90/90	4
7	SHIM	2x170x250	4
8	SUPPORT PLATE	25x100x180	4
9	TAPER PIN	10x100	2
10	JACKING SCREW	M16x55	4

THE TAPER PIN (PART 9) IS NEEDED ONLY AT DRIVE-END OF THE MOTOR.
 X) THE TAPE IS NOT INCLUDED IN THE DELIVERY.

ANCHOR BOLT TO BE MOUNTED IN THE FOUNDATION.
 FOUNDATION STUD WILL BE DELIVERED AS LOOSE ITEMS.
 ONE SET INCLUDES PARTS FOR ONE MACHINE (4 PCS).

Figure 3-1 Typical foundation stud assembly

In order to assemble the foundation stud or sole plate set, the machine must be suspended above the floor by a crane. Proceed as follows, see Figure 3-1 Typical foundation stud assembly:

- Clean the parts protected by an anti-corrosive coating with white spirit
- Screw the greased leveling screws into the foundation studs (part 5) or sole plates
- Wrap a layer of tape around the upper part of the anchor bolts (part 2) according to Figure 3-1 Typical foundation stud assembly. The tape will prevent the upper part of the bolt from being stuck in the concrete and enables it to be retightened after the concrete has set
- Fit the anchor bolt (part 2) in the foundation plates (part 1) or sole plates so that the top of the anchor bolts is 1...2 mm (40...80 mil) above the upper surface of the nuts (part 4)
- Fit the anchor flange (part 3) and the lower nut (part 4) to the anchor bolts (part 2). Bridge the anchor flange (part 3) to the bolts by welding and tighten the nuts. If the bridging cannot be done, lock the anchor flange between two nuts

- After the assembly of the foundation plates is done; the machine should be lifted up and suspended above the floor. The machine feet, and the side and bottom surfaces of the foundation plates as well as anchor bolts should be cleaned with white spirit
- Mount the assembled foundation studs or sole plates under the machine feet with the mounting bolt (part 6) and washer (part 3). Center the mounting bolt (part 6) in the hole of the machine by wrapping e.g. paper, cardboard or tape on the upper part of the bolt
- Place the 2 mm (0.8 inch) shim (part 7) between the foot and the plate (part 1). Fasten the plate tightly against the foot with the mounting bolt (part 6)
- Place the leveling plate (part 8) under the leveling screw (part 5)
- Check that the space between the plate (part 1) and the anchor bolts (part 2) is tight. If concrete penetrates through this interstice up to the nuts, the retightening cannot be done.

NOTE: The tape and the steel plate are not included in the delivery of the foundation studs.

3.4.4 Erection of machines

The machine is carefully lifted and placed onto the foundation. A rough horizontal alignment is made with the aid of the previously installed steel wire and the marking of the axial location. A vertical alignment is made with the leveling screws. Required positioning accuracy is within 2 mm (80 mil).

3.4.5 Alignment

The alignment is made as described in *Chapter 3.6 Alignment*.

3.4.6 Grouting

The grouting of the machine into the foundation is a very important part of the installation. The instructions of the grouting compound supplier must be followed.

Please use high-quality non-shrinking grouting materials to avoid difficulties with the grouting in the future. Cracks in the grouting compound or a poor attachment to the concrete foundation cannot be accepted.

3.4.7 Final installation and inspection

After the concrete has set, lift the machine from the foundation and retighten the anchor bolts. Lock the nuts by bridging or hitting sufficiently hard with a center punch. Lift the machine back on the foundation and tighten the mounting bolts.

Check the alignment in order to ensure that the machine will run with the permissible vibration. If necessary, make the adjustment with shims, and then complete the doweling according to the holes in the feet at the machine D-end.

3.4.7.1 Dowelling of the machine feet

The machine has one dowel hole per foot at the D-end. Deepen the holes by drilling through to the steel foundation. After that, the holes are tapered with a reaming tool. Suitable tapered pins are fitted to the holes to ensure the exact alignment, and to allow easier reinstallation after any possible removal of the machine.

3.4.7.2 Covers and enclosures

Complete the coupling installation by attaching both coupling halves to each other according to the coupling manufacturer's instruction.

NOTE: The coupling must be covered with a touch guard.

After the machine has been erected, aligned and its accessories are installed, check carefully that no tools or foreign objects have been left inside of the enclosures. Clean also any dust or debris.

Check that all sealing strips are intact when installing the covers.

Store the alignment and assembly accessories together with the transport locking devices for future use.

*****Following chapter for mounting type: Horizontal with steel foundation**

3.5 Installation on steel foundation

3.5.1 Scope of delivery

The machine delivery does not normally include installation, shim plates or mounting bolts. These are delivered according to special orders.

If new fixing holes need to be drilled, please contact ABB to ensure suitability.

3.5.2 Check of foundation

Before lifting the machine onto the foundation, the following checks should be made.

- Clean the foundation carefully
- The foundations shall be flat and plain parallel within 0.1 mm (4.0 mil) or better
- The foundation shall be free from external vibration.

3.5.3 Erection of machines

The machine is carefully lifted and placed onto the foundation.

3.5.4 Alignment

The alignment is made as described in *Chapter 3.6 Alignment*.

3.5.5 Final installation and inspection

3.5.5.1 Doweling of the machine feet

The machine has one dowel hole per foot at the D-end. Deepen the holes by drilling through to the steel foundation. After that, the holes are tapered with a reaming tool. Suitable tapered pins are fitted to the holes to ensure the exact alignment, and to allow easier reinstallation after any possible removal of the machine.

3.5.5.2 Covers and enclosures

Complete the coupling installation by attaching both coupling halves to each other according to the coupling manufacturer's instruction.

NOTE: The coupling must be covered with a touch guard.

After the machine has been erected, aligned and its accessories are installed, check carefully that no tools or foreign objects have been left inside of the enclosures. Clean also any dust or debris.

Check that all sealing strips are intact when installing the covers.

Store the alignment and assembly accessories together with the transport locking devices for future use.

*****Following chapter only for mounting type: Vertical**

3.5.6 Installation of flange mounted machines on steel foundation

The purpose of a mounting flange for vertically mounted machines is to enable an easy installation and coupling connection, as well as an easy inspection of the coupling during operation. In order to fit the ABB machines, the mounting flanges shall be designed according to the IEC standard.

The mounting flange is not included in the ABB scope of delivery.

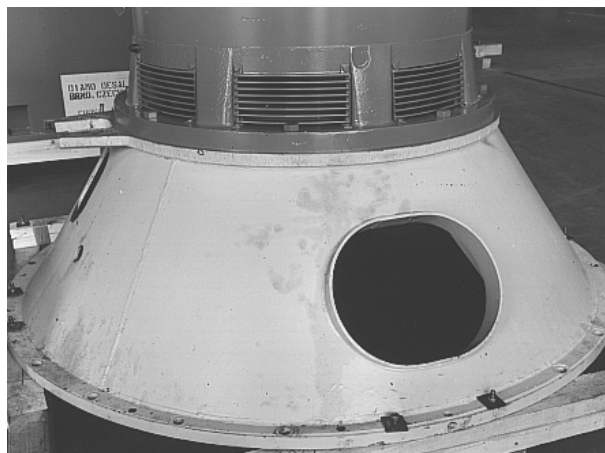

Figure 3-2 Mounting flange

The machine is lifted and placed onto the mounting flange. The mounting bolts are tightened lightly.

3.6 Alignment

3.6.1 General

In order to ensure a long and satisfactory lifetime of both the driving and the driven machine, the machines need to be properly aligned to each other. This means that the radial, as well as the

angular deviation between the two shafts of the machines have to be minimized. The alignment must be performed with great caution because alignment errors will lead to bearing and shaft damages.

Before the alignment procedure is started, the coupling halves have to be installed, see *Chapter 3.3.4 Assembly of the coupling half*. The coupling halves of the driving and driven machines must be bolted together loosely in order to move freely in respect to each other during the alignment.

The following text refers to installation on both concrete and steel foundations. Shimming is not necessary in case of a concrete foundation if the alignment and grouting is done correctly.

3.6.2 Rough levelling

In order to facilitate the alignment and enable the mounting of shims, jacking screws are fitted to the feet of the machine, see *Figure 3-3 Vertical positioning of machine foot*. The machine is left standing on the jacking screws. Note that the machine must stand on all four feet (screws) on a plain parallel within 0.1 mm (4.0 mil) or better. If this is not the case, the frame of the machine will be twisted or bent, which can lead to bearing or other damages.

Check that the machine is vertically, horizontally and axially in level. Make adjustments accordingly by placing shims under the four feet. The horizontal level of the machine is checked with a spirit level.

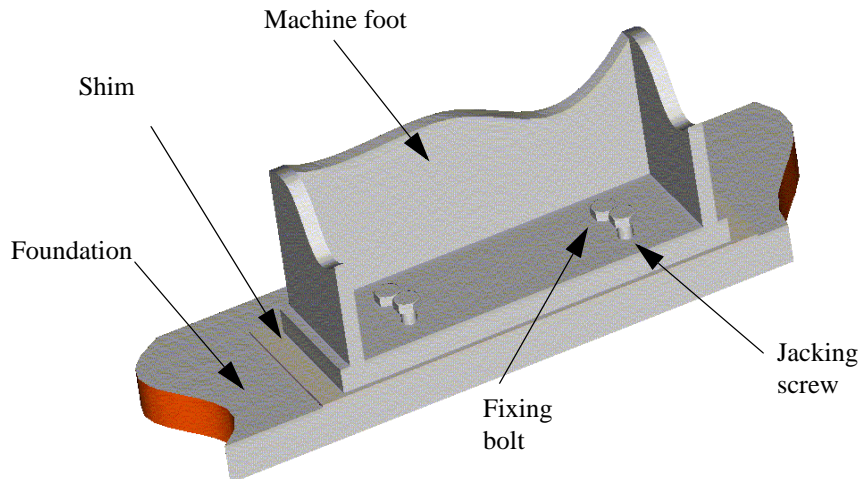

Figure 3-3 Vertical positioning of machine foot

3.6.3 Rough adjustment

In order to facilitate the alignment in axial and transversal directions, place bracket plates with adjusting screws at the corners, see *Figure 3-4 Positioning of bracket plates*.

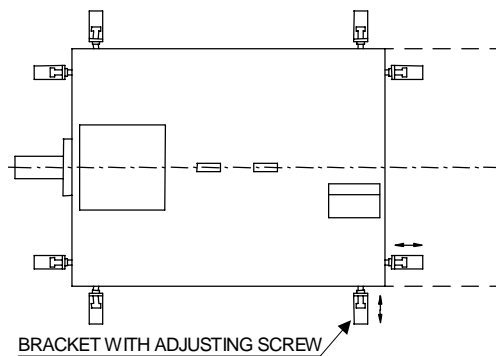

Figure 3-4 Positioning of bracket plates

Bracket plates are placed against the foundation edge and tied down with expansion bolts, see *Figure 3-5 Mounting of the bracket plate*. Move the machine by using the adjusting screws until the shaft centerline and the driven machine centerline are aligned roughly and the desired distance between the coupling halves is reached. Leave all adjusting screws only lightly tightened.

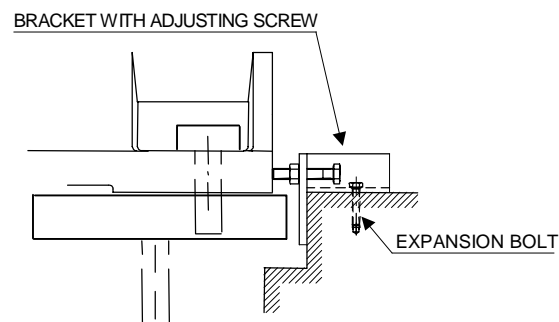

Figure 3-5 Mounting of the bracket plate

NOTE: *Figure 3-5 Mounting of the bracket plate* shows bracket plate mounted to concrete foundation, place similar bracket plate on steel foundation.

*****Following paragraph for bearing type: Sleeve bearing with axial float**

The sleeve bearing in the D-end is equipped with a pointer for showing running center, which is marked with a groove on the shaft. There are also grooves on the shaft for rotor mechanical end float limits. The position is correct when the tip of the pointer is in line with the machined running center groove on the shaft, see *Figure 3-6 Markings on shaft and running center pointer*. Notice that the running center is not necessarily the same as the magnetic center as the fan may pull the rotor from the magnetic center.

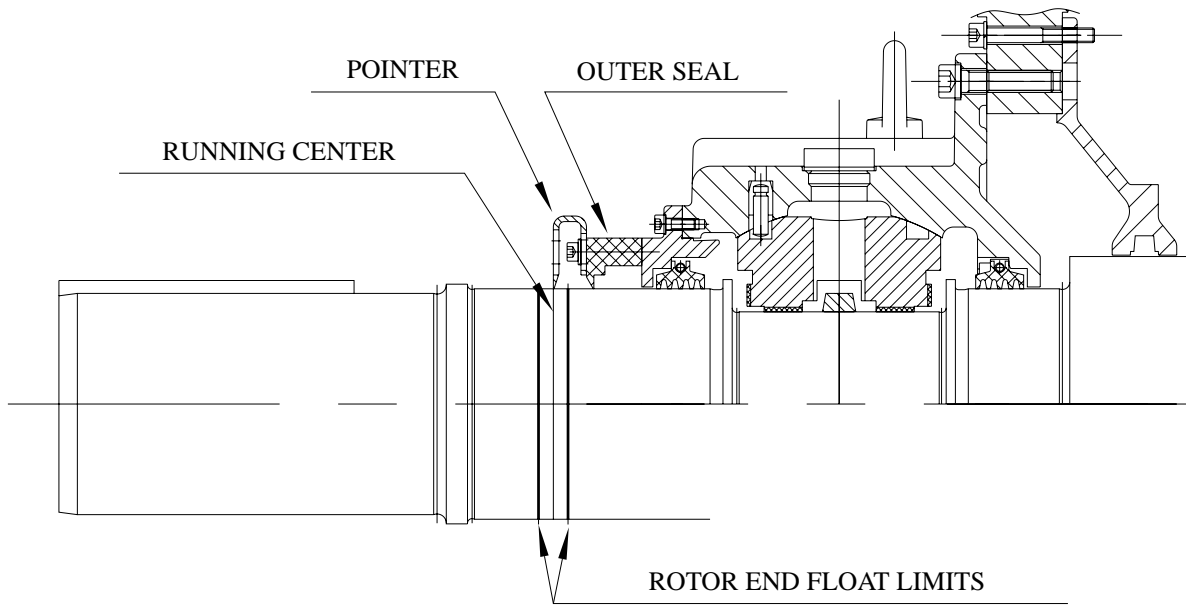

Figure 3-6 Markings on shaft and running center pointer

3.6.4 Correction for thermal expansion

3.6.4.1 General

Running temperatures have a considerable influence on the alignment, and should therefore be considered during the alignment. The machine temperature is lower during erection than under operating conditions. For this reason, the shaft center will be higher, i.e. further away from the feet during operation than standstill.

It may therefore be necessary to use heat compensated alignment depending on the operating temperature of the driven machine, coupling type, distance between machines, etc.

3.6.4.2 Thermal expansion upwards

The thermal expansion of the distance between the feet and the shaft center of the electrical machine can be approximately calculated according to the formula:

$$\Delta H = \alpha \times \Delta T \times H \text{ where}$$

$$\Delta H = \text{thermal expansion [mm]}$$

$$\alpha = 10 \times 10^{-6} \text{ K}^{-1}$$

$$\Delta T = 40 \text{ K}$$

$$H = \text{shaft height [mm]}$$

NOTE: Consider the thermal expansion of the driven machine in respect to the electrical machine in order to define the total thermal expansion.

3.6.4.3 Thermal axial growth

The thermal axial expansion needs to be taken into consideration if the axial movement of the non-drive end bearing is locked. See the dimension drawing in order to determine which end is locked.

The expected axial thermal expansion of the rotor is proportional to the length of the stator frame, and can be approximately calculated according to the formula:

$$\Delta L = \alpha \times \Delta T \times L \text{ where}$$

ΔL =thermal expansion[mm]

$$\alpha = 10 \times 10^{-6} \text{ K}^{-1}$$

ΔT =50 K (for AMA, AMB, AMK, AMI), 80 K (for AMH, HXR, M3BM, M3GM)

L=frame length [mm]

NOTE: Make sure that a continuous free axial movement is possible between the coupling halves (excluding rigid couplings) in order to permit axial thermal expansion of the machine shaft as not to damage the bearings.

3.6.5 Final alignment

3.6.5.1 General

In the following, the final alignment is made with dial gauges, although there is other and more exact measuring equipment on the market. The reason for using dial gauges in this text is to provide some alignment theory.

NOTE: Measurements should be made only after proper shimming and with fixing bolts properly tightened.

NOTE: The final alignment measurements should always be recorded for future reference.

3.6.5.2 Run-out of the coupling halves

The alignment procedure is started by measuring the run-out of the coupling halves. This measurement will show any inaccuracy of the shaft and/ or coupling halves.

The run-out of the coupling half in respect to the bearing housing of the machine is measured. Place the gauges according to *Figure 3-7 Measuring the run-out at the coupling half*. Similarly check the run-out of the coupling half of the driven machine in respect to its bearing housing.

A simple lever arm is needed to turn a rotor of a sleeve-bearing machine.

*****Following note for bearing type: Sleeve bearings**

NOTE: Sleeve bearings must be filled with oil before turning.

The admissible run-out error is less than 0.02 mm (0.8 mil).

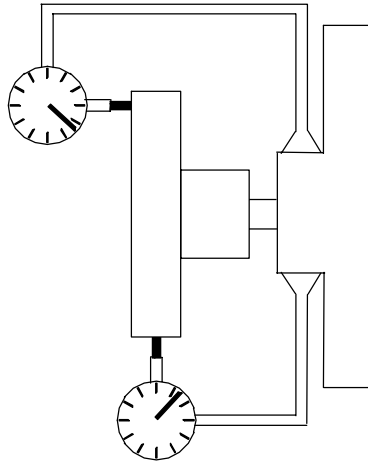

Figure 3-7 Measuring the run-out at the coupling half

3.6.5.3 Parallel, angular and axial alignment

After the machine has been roughly positioned, as described in *Chapter 3.6.2 Rough levelling* and *Chapter 3.6.3 Rough adjustment*, the final alignment can start. This step must be performed with great caution. Failure to do so can result in serious vibrations and damage to both driving and driven machine.

The alignment is done in accordance with the recommendations given by the coupling manufacturer. Parallel, angular and axial alignment of the machine is required. Some standard publications give recommendations for coupling alignment, e.g. BS 3170:1972 "*Flexible couplings for power transmission*".

In accordance with common practice, parallel and angular misalignment should not exceed 0.05-0.10 mm and axial misalignment should not exceed 0.10 mm, see *Figure 3-8 Definition of misalignment*. The corresponding run-out is 0.10-0.20 mm for parallel and angular misalignment.

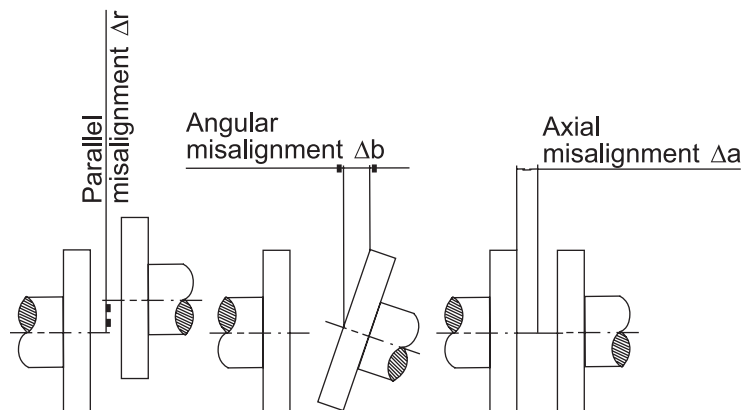

Figure 3-8 Definition of misalignment

3.6.5.4 Alignment

The alignment of the machine is performed according to these guidelines.

1. The machine should stand on its jacking screws
2. Rotate the rotor and check the axial end float, see *Chapter 3.6.3 Rough adjustment*

***Following note for bearing type: Sleeve bearings

NOTE: Sleeve bearings must be filled with oil before turning.

3. Mount the alignment equipment. If gauges are used, it is practical to adjust the dial gauge in such way that approximately half of the scale is available in either direction. Check the rigidity of the gauge brackets in order to eliminate the possibility of sag, see *Figure 3-9 Alignment check with gauges*

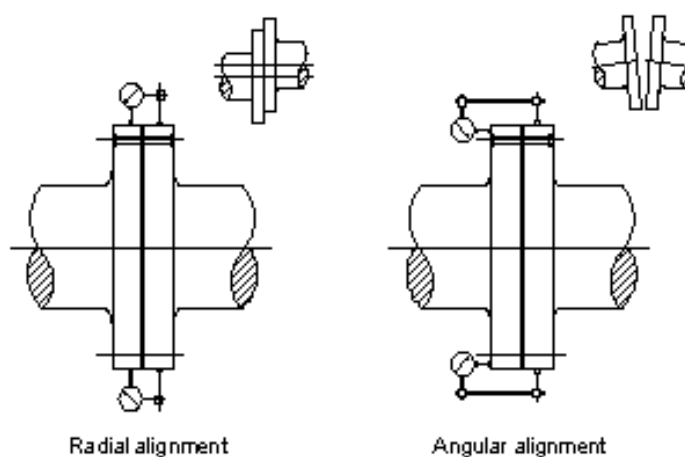

Figure 3-9 Alignment check with gauges

4. Measure and note readings for parallel, angular and axial misalignment in four different positions: top, bottom, right and left, i.e. every 90°, while both shafts are turned simultaneously. The readings are recorded
5. Align the machine vertically by turning the jacking screws or by jacking with hydraulic jacks. To facilitate the alignment in the vertical plane, jacking screws are fitted to the feet of the horizontal machine, see *Figure 3-3 Vertical positioning of machine foot*. The alignment accuracy of the machine is sometimes affected by the thermal expansion of its frame, see *Chapter 3.6.4 Correction for thermal expansion*
6. Measure the distance between the bottom of the machine feet and the bedplate and make corresponding solid blocks or wedges or reserve necessary amount of shims
7. Fit the solid blocks or shims under the machine feet. Slacken the jacking screws and tighten the fixing bolts
8. Check the alignment again. Make corrections if necessary
9. Draw up a record for future checks
10. Re-tighten nuts and lock the nuts by tack welds or hitting sufficiently hard with a center punch
11. Dowel the feet of the machine for easy future re-installation of the machine, see *Chapter 3.4.7.1 Dowelling of the machine feet*.

3.6.5.5 Permissible misalignment

Definite alignment tolerances are impossible to state as too many factors have an influence. Too large tolerances will cause vibration and may possibly lead to bearing or other damages. Therefore, it is recommended to aim at as narrow tolerances as possible. Maximum permissible misalignments are shown in *Table 3-1 Recommended permissible misalignments* For definitions of misalignment, see *Figure 3-8 Definition of misalignment*.

NOTE: Tolerances given by the coupling manufacturers indicate tolerances for the coupling, not for the driving-driven machine alignment. The tolerances given by the coupling manufacturer should be used as a guideline for the alignment only if they are narrower than the maximum permissible misalignments shown in *Table 3-1 Recommended permissible misalignments*.

Table 3-1. Recommended permissible misalignments

Coupling Information		Permissible Misalignment		
Coupling Diameter	Coupling Type	Parallel Δr	Angular Δb	Axial Δa
100 – 250 mm (4 – 10")	Rigid Flange	0.02 mm (0.8 mil)	0.01 mm (0.4 mil)	0.02 mm (0.8 mil)
	Gear	0.05 mm (2 mil)	0.03 mm (1 mil)	0.05 mm (2 mil)
	Flexible	0.10 mm (4 mil)	0.05 mm (2 mil)	0.10 mm (4 mil)
250 – 500 mm (10 – 20")	Rigid Flange	0.02 mm (0.8 mil)	0.02 mm (0.8 mil)	0.02 mm (0.8 mil)
	Gear	0.05 mm (2 mil)	0.05 mm (2 mil)	0.05 mm (2 mil)
	Flexible	0.10 mm (4 mil)	0.10 mm (4 mil)	0.10 mm (4 mil)

3.7 Care after installation

If the machine will not be in operation for a longer period after it has been installed, the same measures as mentioned above in *Chapter 2.6.1 Short term storage (less than 2 months)* should be applied. Remember to rotate the shaft 10 revolutions at least every 3 months, and that self-lubricated bearings must be filled with oil. If external vibration is present, the shaft coupling should be opened and suitable rubber blocks should be placed under the feet of the machine.

*****Following note for bearing type: Rolling bearing**

NOTE: External vibration will damage the bearing rolling surfaces and therefore shorter the bearing lifetime.

*****Following note for bearing type: Sleeve bearing**

NOTE: External vibration will damage the bearing sliding surfaces and therefore shorter the bearing lifetime.

Chapter 4 Mechanical and Electrical Connections

4.1 General

Mechanical and electrical connections are made after the installation and alignment procedures. The mechanical connections include the connection of air ducts, water tubes and/or oil supply system where applicable.

The electrical connections include the connection of main and auxiliary cables, earthing cables and possible external blower motors.

In order to determine proper actions, please read the Dimensional Drawing, the Connection Diagram and the Data Sheet provided with the machine.

NOTE: Additional installation holes or threads should never be drilled through the frame, as this may damage the machine.

4.2 Mechanical connections

******Following chapter for cooling method: Ducted air***

4.2.1 Cooling air connections

Machines designed for cooling airflow to and/or from the machine with air ducts have connection flanges as specified in the dimensional drawing.

Clean the air ducts thoroughly before connecting them to the machine, and check for possible obstructions in the ducts. Seal the joints with appropriate gaskets. Check for possible leaks in the air ducts after they have been connected.

******Following chapter for cooling method: Air-to-water, and water jacket***

4.2.2 Cooling water connections

******Following chapter for cooling method: Air-to-water***

4.2.2.1 Air-to-water coolers

Machines equipped with an air-to-water heat exchanger have flanges specified in standards DIN 633 or ANSI B 16.5. Connect the flanges and seal the joints with appropriate gaskets. Prior to starting the machine, the water has to be turned on.

******Following chapter for cooling method: Water jacket***

4.2.2.2 Water cooled frames

Steel frame water-cooled construction is only to be used with a closed fresh water circulation. The water cooling circuit flanges are made according to the customer's specifications, and are defined on the dimensional drawing.

The cooling water circulates in ducts integrated in the machine frame. The material of the frame and ducts is carbon steel according to the standard EN 10025: S235 JRG2, equivalent with DIN 17100 - RSt 37-2. This material is prone to corrosion in saline and foul water. The corrosion products and fouling deposits might block the water flow in the ducts. This is why it is important to use pure and inhibited water in the cooling system.

Standard values for the cooling water to be used in the cooling system:

- pH 7.0 - 9.0
- Alkalinity (CaCO₃) ≥ 1 mmol/kg
- Chloride (Cl) < 20 mg/kg
- Sulphate < 100 mg/kg
- KMnO₄-concentration < 20 mg/kg
- Al-concentration < 0.3 mg/kg
- Mn-concentration < 0.05 mg/kg

In most of the cases, normal tap water, i.e. water for domestic consumption, fulfils all these requirements.

The cooling water must also be inhibited with an agent protecting the cooling system against corrosion, fouling and when necessary, against freezing. All materials in touch with the cooling water (pipes, heat exchanger, etc.) must be taken into account when selecting a suitable inhibitor.

Recommended inhibitor:

Manufacturer	ASHLAND
Product	RD-25

which is suitable for steel, copper, aluminium and many other materials.

Use only suitable and high-class connection parts and seals to connect the machine to the water circuit. Check for possible leaks after the piping and joints have been connected.

*****Following chapter for bearing type: Sleeve bearing**

4.2.3 Sleeve bearing oil supply

Machines with flood lubrication system are equipped with oil pipe flanges, and possibly with pressure gauges and flow indicators. Install all necessary oil pipes and connect the oil circulating units.

Install the oil supply system near the machine in equal distance from each bearing. Before connecting the pipes to the bearings, test the oil supply system by flowing rinsing oil through it. After this, remove the oil filter and clean it.

Install and connect the oil inlet pipes to the bearings. Install the oil outlet pipes downwards from the bearings at a minimum angle of 15°, which corresponds to a slope of 250 - 300 mm/m (3 - 3½ inch/ft). The oil level inside the bearing will increase if the slope of the pipes is too small; the oil will flow too slowly from the bearing to the oil container, and this can result in oil leaks or disturbances in the oil flow.

NOTE: Do not drill holes through the frame during the installation of the pipes or any other equipment, as this can damage the machine seriously.

Fill the oil supply system with appropriate oil with correct viscosity. The correct type of oil and viscosity is indicated on the dimensional drawing. If in any doubt of the cleanness of the oil, use a 0.01 mm (0.4 mil) mesh to filter unwanted debris from the oil.

Turn the oil supply on, and check the oil circuit for possible leaks prior to starting the machine. The normal oil level is obtained when half of the oil sight glass is covered.

NOTE: The bearings are delivered without lubricant.

NOTE: Running the machine without lubricant will result in immediate bearing damage.

*****Following chapter for protection type: Ex p**

4.2.4 Connection of purging air pipe

The EEx p or Ex p machine is explosion protected by pressurizing. It is equipped with a control system, which includes an air control unit and a relief valve. The system works with uncontaminated pressurized air as the protective gas. Before the start, the machine is purged to remove any hazardous gases. During operation, the machine is kept under over-pressure to keep hazardous gases from entering the machine.

Purging and pressurizing air supply is connected to the flange provided on the air control unit. The air supply pressure must be between 4 and 8 bar. Required flow rate during purging and pressurizing is specified on the Ex - certificate. For more detailed information of the control system, see the supplier's instruction manual.

4.2.5 Mounting of vibration transducers

If the installed vibration transducers project from the machine frame, they are delivered uninstalled in order to avoid damages during transportation.

For taking vibration transducers into use, proceed as follows:

1. Disconnect the detached vibration transducers from their cables.
2. Remove the shield plugs from the tapped mounting holes on the end shield of the machine.
3. Protect the mounting surfaces against rust with a suitable anti-corrosion agent.
4. Mount the vibration transducers to the tapped mounting holes. The tightening torque depends on the used transducer type:
 - PYM TRV18 : 10 Nm
 - PYM 330400_ : 3,3 Nm
 - PYM 330500_ : 4,5 Nm
5. Finally, connect the cables to the vibration transducer.

4.3 Electrical connections

4.3.1 General information

The safety information in *Safety Instructions* at the beginning of the manual must be observed at all times.

The electrical installation should be thoroughly planned before taking any action. The connection diagrams received with the machine have to be studied before starting the installation work. It is important to verify that the supply voltage and the frequency are the same as the values indicated on the rating plate of the machine.

The network voltage and frequency should be within given limits according to the applicable standard. Note rating plate markings and connection diagram in the terminal box. For additional information, see the machine performance data sheet.

NOTE: Prior to installation work, it is important to check that the incoming cables are separated from the supply network, and that the cables are connected to protective earth.

NOTE: Check all rating plate data, especially the voltage and winding connection.

*****Following paragraph for rotor type: Permanent magnet**

Machines are intended only for variable speed drives, i.e. to be supplied by frequency converters. The frequency converter must be designed to operate with a permanent magnet synchronous machine. If there is uncertainty concerning the compatibility of the permanent magnet synchronous machine and the frequency converter, please contact ABB Sales Office.

4.3.2 Safety

Electrical work must be carried out only by skilled persons. The following safety rules must be applied:

- De-energize all equipment, including auxiliary equipment
- Provide safeguard against re-energizing the equipment
- Verify that all parts are isolated from their respective supply
- Connect all parts to protective earth and short the circuits
- Cover or provide barriers against live parts in the surrounding area
- If the secondary circuit of the current transformer is extended, make sure that it does not become open-circuited in use

*****Following bullet for rotor type: Permanent magnet rotor**

- The permanent magnet synchronous machine produces voltage when the shaft is rotating. Prevent rotation of the shaft before opening the terminal box. Do not open or touch the unprotected terminals while the shaft of the machine is rotating. Follow *Safety Instructions* at the beginning of the manual.

4.3.3 Insulation resistance measurements

Before a machine is started up for the first time, after a long period of standstill or within the scope of general maintenance work, the insulation resistance of the machine must be measured, see *Chapter 7.6.4 Insulation resistance test*.

4.3.4 Main terminal box options

The inside of the main terminal box must be free from dirt, moisture and foreign debris. The box itself, cable glands, and unused cable entrance holes must be closed in a dust- and watertight manner.

The main terminal box is equipped with a drain plug at the lowest part of the box. The plug should be in open position, i.e. half of the plug is inside and half of the plug is outside, during transportation and storage. During operation of the machine, the plug should be kept in shut position but opened from time to time. If the box is turned after delivery the drain plug function must be checked, and possibly re-positioned at the lowest part of the box.

Some main terminal boxes can be turned in 90 degrees steps. Before turning, check that the length of the cables between the stator winding and the terminal box is sufficient.

4.3.4.1 Delivery without main terminal box

If the machine is delivered without a main terminal box, the stator connection cables have to be covered with earthed protective structure before commissioning. The structure must have the same or higher enclosure classification and hazardous area certifications as the machine.

To avoid cable failure, stator connection cables must be shortened to minimize free movement of the cables. The supplier of the terminal arrangement is responsible for ensuring that adequate stator connection cable supports are used. The stator connection cable arrangement has to be spacious in order to avoid overheating of the cables. Stator connection cables must not touch sharp corners. The minimum bending radius of stator connection cable is 6 times the cable outer diameter.

4.3.5 Insulation distances of main power connections

The connections of the main power cables must be designed to withstand demanding operation conditions where the insulators can be subjected to dirt, humidity and surge voltages. In order to ensure lasting and trouble-free running, it is therefore important that the length of the insulation and creepage distances are sufficient. The minimum insulation and creepage distances should be equal or exceed demands set by:

- Local requirements
- Standards
- Classification rules
- Hazardous area classification.

The insulation and creepage distances apply both for insulation distances between two different phases, and for insulation distances between one phase and earth. The air insulation distance is the shortest distance through air between two points with different electrical potential (voltage). The surface creepage distance is the shortest distance along surfaces next to each other between two points with different electrical potential (voltage).

4.3.6 Main power cables

The size of the input cables has to be adequate for the maximum load current and in accordance with local standards. The cable terminals have to be of appropriate type and of correct size. The connection to all devices has to be checked.

The main power cable connections should be tightened correctly to ensure reliable operation. For details, see *Appendix Typical main power cable connections*.

*****Following note for protection type: All hazardous areas**

NOTE: For Ex-machines, cable glands or cable bushings for supply cables must be Ex certified. Glands or bushings are not included in the manufacturer's delivery.

NOTE: Prior to installation work, it is important to check that the incoming cables are separated from the supply network, and that the cables are connected to protective earth.

The stator terminals are marked with letters U, V and W according to IEC 60034-8 or T1, T2, and T3 according to NEMA MG-1. The neutral terminal is marked with N (IEC) or with T0 (NEMA). Stripping, splicing and insulating of the high-voltage cables must be performed in accordance with instructions by the cable manufacturer.

The cables must be supported so that no stress is applied to the bus bars in the terminal box.

NOTE: Check the phase sequence from the connection diagram.

*****Following paragraph for rotor type: Permanent magnet rotor**

NOTE: Permanent magnet synchronous machines must be cabled by using shielded symmetrical cables and cable glands providing 360° bonding (also called EMC glands).

*****Following paragraph for rotor type: Slip rings**

4.3.7 Secondary cables for slip ring connections

The slip ring housing at the non-drive end of the machine serves as a terminal box for the secondary cables, and it has the same degree of protection as the machine.

The cables can be connected from either side. The connection is made to the rotor terminals on the termination plate, which is designed to fit up to six cable lugs per phase. The terminals are marked K, L and M in accordance with IEC Publications 60034-8.

NOTE: Study the connection diagram delivered with the machine carefully before connecting any cables.

4.3.8 Auxiliary terminal box

Auxiliary terminal boxes are attached to the frame of the machine according to accessories and customer needs, and their positions are shown on the dimensional drawing of the machine.

The auxiliary terminal boxes are equipped with terminal blocks and cable glands, see *Figure 4-1 Typical auxiliary terminal box*. The maximum size of the conductors is normally limited to 2.5 mm² (0.004 sq. in.), and the voltage is limited to 750 V. The cable glands are suitable for cables of 10 – 16 mm (0.4"– 0.6") diameter.

*****Following note for protection type: All machines for hazardous areas**

NOTE: For Ex-machines, cable glands or cable bushings for supply cables must be Ex certified. Glands or bushings are not included in manufacturer's delivery.

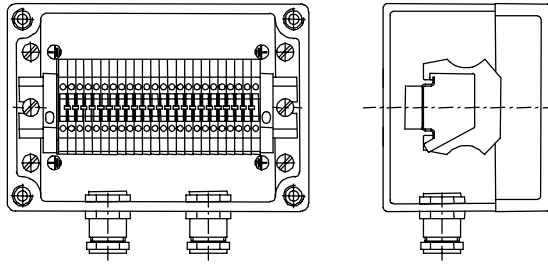

Figure 4-1 Typical auxiliary terminal box

4.3.8.1 Connection of auxiliaries and instruments

Connect the instruments and auxiliary equipment according to the connection diagram.

NOTE: Study the connection diagram delivered with the machine carefully before connecting any cables. The connection and functioning of accessories must be checked before commissioning.

NOTE: Label terminals of accessories, which are normally under voltage when the machine is switched off, correspondingly.

4.3.8.2 Connection of external blower motor

The external blower motor is normally a three phase asynchronous motor. A connection box is usually located on the frame of the blower motor. The external blower motor rating plate shows the voltage and frequency to be used. The direction of rotation of the fan is indicated by an arrow plate on the flange of the main machine.

NOTE: Check visually the direction of rotation of the external blower motor (fan) before starting the main machine. If the blower motor is running in the wrong direction, the phase sequence of the blower motor must be changed.

4.3.9 Earth connections

The machine frame, main terminal box, auxiliary terminal box and associated equipment must be connected to protective earth. The connections to protective earth and power supply have to be able to protect the machine frame from harmful or dangerous electrical potential (voltage).

NOTE: The earthing must be carried out according to local regulations before the machine is connected to the supply voltage.

NOTE: The warranty does not cover destroyed bearings due to improper earthing or cabling.

Mark the machine and terminal boxes with earth symbols according to relevant national standards.

*****Following chapter for application type: Variable speed drive**

4.3.10 Requirements for machines fed by frequency converters

In compliance with the EMC directive (89/336/ EEC, as amended by 93/68/EEC) it is required that an AC machine fed with frequency converter is installed with screened cables as specified below. For information on other equivalent cables, please contact your local ABB representative.

4.3.10.1 Main cable

The main supply cable between the machine and the frequency converter must be a symmetrical three conductor screened cable in order to fulfil the radiated emission requirements stated in the generic emission standard for industrial environment, EN 50081-2. For further information, see ABB manual *Grounding and cabling of the drive system (3AFY 61201998 R0125 REV A)*.

4.3.10.2 Earthing of main cable

The compliance with EMC directive requires high-frequency earthing of the main cable. This is achieved by a 360° earthing of the cable screens at the cable entries in both the machine and in the frequency converter. The earthing at the machine is implemented for example by means of the EMC ROX SYSTEM cable transits for shielded installations.

NOTE: 360° high-frequency earthing of cable entries is made in order to suppress electromagnetic disturbances. In addition, cable screens have to be connected to protective earth (PE) in order to meet safety regulations.

4.3.10.3 Auxiliary cables

The auxiliary cables must be screened to meet the EMC requirements. Special cable glands must be used for the 360° high-frequency earthing of the cable screens at the cable entries.

Chapter 5 Commissioning and Start-up

5.1 General

A commissioning report is a vital tool for future service, maintenance and fault finding.

The commissioning is not to be considered finalized before an acceptable commissioning report has been documented and filed.

The commissioning report has to be available in warranty requests in order to obtain warranty for the machine. For contact information, see *Chapter 9.1.5 After Sales contact information*.

The recommended commissioning report can be found in *Appendix COMMISSIONING REPORT*.

5.2 Check of mechanical installation

Check alignment of the machine prior to commissioning:

- Go through the alignment report and ensure that the machine is accurately aligned according to ABB alignment specifications in *Chapter 3.6 Alignment*
- The alignment protocol should always be included in the commissioning report

Check that the machine is properly anchored to the foundation:

- Check for cracks in the foundation and the general condition of the foundation
- Check the tightness of the mounting bolts.

Additional checks, when applicable:

- Check that the lubrication system is commissioned and is running before the rotor is turned
- If possible, turn the rotor by hand and make sure that the rotor turns freely and that no abnormal sound can be heard
- Check the assembly of the main terminal box and cooling system
- Check the connection of oil and cooling water pipes and check for leaks when running
- Check pressure and flow for oil and cooling water.

5.3 Insulation resistance measurements

Before a machine is started up for the first time, after a long period of standstill or within the scope of general maintenance work, the insulation resistance of the machine must be measured, see *Chapter 7.6.4 Insulation resistance test*.

5.4 Check of electrical installation

The power cables can be permanently connected to the terminals in the main terminal box when the stator insulation resistance has been measured, see *Chapter 7.6.4 Insulation resistance test*.

Check connection of power cables:

- Check that the cable lug bolts are tightened with proper torque

- Check that the power cables are suitably routed
- Check that the power cables are stress-relieved in a proper way
- Check the connections of the auxiliary equipment.

NOTE: If the machine is delivered without a main terminal box, see *Chapter 4.3.4.1 Delivery without main terminal box*.

*****Following note for protection type: All machines for hazardous areas**

NOTE: If an anti-condensation heater, without self-regulation, is turned on immediately after the motor is shut down, take suitable measures to control the inside motor housing temperature. The anti-condensation heaters can only operate within a temperature-controlled environment.

5.5 Control and protection equipment

5.5.1 General

The machine is equipped with temperature detectors to be connected to a temperature monitoring and protection system. The location and type, as well as the settings for these detectors, can be found on the dimensional drawing, and the connection diagram of the machine.

The temperature alarm level for resistance temperature detectors (RTD, Pt-100) should be set as low as possible. The level can be determined based on the test results, or the noticed operating temperature. The temperature alarm can be set 10K (20°F) higher than the operating temperature of the machine during maximal load at highest ambient temperature.

If a two-function temperature monitoring system is used, the lower level is normally used as an alarm level and the higher as a trip level.

NOTE: In case the machine trips, the reason must be found and eliminated before the machine is restarted. In case of an alarm, find the reason and correct the situation. Use the trouble shooting guide, see *Chapter 8.1 Trouble shooting*.

*****Following note for rotor type: Permanent magnet rotor**

NOTE: Permanent magnet synchronous machines are equipped with Pt100 resistance elements and/or thermistors. The use of these protective elements is mandatory to avoid the risk of overloading the machine.

5.5.2 Stator winding temperature

5.5.2.1 General

The stator windings are manufactured according to temperature rise class F, which has a temperature limit of 155°C (300°F). A high temperature will age the insulation and shorten the lifetime of the winding. Therefore, thorough consideration should be made when deciding the temperature trip and alarm levels for the winding.

5.5.2.2 Resistance temperature detectors

Recommended maximum temperature settings:

For determining the temperature settings, see the Connection Diagram delivered with the machine. It is recommended to apply the method described in *Chapter 5.5.1 General* when setting the temperature alarm.

5.5.2.3 Thermistors

If the machine is equipped with thermistors (PTC), the operating temperature of the thermistors is found on the Connection Diagram. The operating function can be chosen to be an alarm or a trip signal. If the machine is equipped with six thermistors, both alarm and trip signals can be used respectively.

5.5.3 Bearing temperature control

5.5.3.1 General

The bearings can be equipped with temperature detectors for monitoring the bearing temperatures. The viscosity of the grease or oil used will become smaller as a function of higher temperature. When the viscosity falls below a certain limit, the ability to form a lubricating film inside the bearing will cease, and the bearing will fail, and possibly, shaft damage will occur as a result.

If the machine is equipped with resistance temperature detectors, the temperature of the bearings should preferably be monitored continuously. If the temperature of a bearing unexpectedly starts to rise, the machine should be shut down immediately, as the temperature rise might indicate a bearing failure.

5.5.3.2 Resistance temperature detectors

Recommended maximum temperature settings:

For determining the temperature settings, see the Connection Diagram delivered with the machine. It is recommended to apply the method described in *Chapter 5.5.1 General* when setting the temperature alarm.

5.5.3.3 Thermistors

If the rolling bearings are equipped with thermistors (PTC), the operating temperature of the thermistors is found on the Connection Diagram. The operating function can be chosen to be an alarm or a trip signal. If the rolling bearings are equipped with two thermistors, both alarm and trip signals can be used respectively.

5.5.4 Protection equipment

The machine has to be protected against various disturbances, faults and overloading that might damage the machine. The protection must be in accordance with the instructions and regulations for each country where the machine is used.

The machine parameter values for relay settings are informed in the document “Performance data of machine” which is included in the documentation provided with the machine.

NOTE: The machine manufacturer is not responsible for the adjusting the protection equipment at the site.

5.6 First test start

5.6.1 General

The first test start is a standard procedure after the installation and alignment procedure is finished, the mechanical and electrical connections are made, the commissioning procedure is gone through and the protective devices are active.

NOTE: If possible, the first start is made with uncoupled coupling between the driving and driven machine. The load on the machine must in any case be as small as possible.

5.6.2 Precautions before first test start

A visual inspection of the machine and its equipment is made before the first test start. It is verified that all necessary tasks, checking and adjustments have been performed.

Before the test start, the following checks and measures must be made:

- If the coupling half is not assembled, the shaft extension key is either locked or removed

*****Following bullet for bearing type: Sleeve bearing**

- The sleeve bearing oil reservoirs and possible oil supply systems are filled with recommended oil to the correct level. The oil supply system is turned on

*****Following bullet for bearing type: Rolling bearing**

- The rotor is turned by hand, and it is verified that no abnormal noises are heard from the bearings. To turn a rotor with sleeve bearings, a simple lever arm is needed

*****Following bullet for cooling method: Air-to-water**

- In case of water-cooled machines, the cooling water is turned on. The tightness of the flanges and the cooling unit is checked
- The cabling, cables and bus bar connections are verified to be according to the connection diagram
- The earth connections and earthing devices are verified
- The starting, control, protection, and alarm relays of each device are inspected
- The insulation resistance of the windings and other equipment verified
- The machine covers are assembled, and the shaft seals are tightly fitted in
- The machine and the environment are cleaned

*****Following bullet for protection type: Ex p**

- Ex machine enclosure has been purged and it is pressurized. Refer to the purging and pressurizing system instructions.

5.6.3 Starting

The first start should last only about one (1) second, during which the direction of rotation of the machine is verified. The direction of rotation of possible external blower motors must also be verified. It is also verified that the rotating parts do not touch any stationary parts.

NOTE: If the machine does not have an axially locating bearing, and the machine is started uncoupled, it is normal that the shaft will move axially before stabilizing.

5.6.3.1 Direction of rotation

The objective of the first starting is to check the direction of rotation of the machine. The machine should turn in the same direction as is shown with an arrow located on the frame or the fan cover. The direction of rotation of the external blower motor is indicated by an arrow near the blower motor. The machine may only be operated in the specified direction of rotation. The direction of rotation is indicated on the marking plate, see *Appendix Typical position of plates*.

Machines suitable for reversing operation are labelled with a double-headed arrow on the rating plate, as well as on the frame.

If the desired direction of rotation for some reason is different from the one specified on the machine, the cooling fans, in inner and/or outer cooling circuit, must be changed, as well as the stamp on the rating plate.

To alter the direction of rotation, interchange the power supply phases.

*****Following chapter for rotor type: Slip rings**

5.6.3.2 Starting of machines with slip rings

Machines with slip rings cannot be operated without a starter. The starter is typically a variable resistance connected to each rotor phase via the slip rings. The selection of the starter is done according to required starting torque and current. Starting is typically done with nominal current and nominal torque.

During starting the starter resistance is decreased and speed for breakdown torque is shifted towards higher speed. The speed of the machine is always between actual breakdown torque speed and synchronous speed. Operation between standstill and breakdown torque, or stalling during starting, is not allowed.

NOTE: Failure in starting the machine without checking the adjustments of the complete slip ring gear can result in serious damage! The connections to the starter and its functions shall also be verified.

NOTE: The brush-lifting device must be in starting position before starting the machine.

*****Following chapter for protection type: Ex p**

5.6.3.3 Starting of Ex p machines

The Ex p machine enclosure is explosion protected during operation by pressurizing. Before pressurizing, the machine enclosure shall be purged with clean air. Detailed commissioning instructions for the purge and pressurization equipment are given in a separate manual. In case

of eventual noticeable air leaks from the machine enclosure, the leaking joints shall be properly sealed.

The purging and pressurizing system must be included in the starting interlocking system. Connect the alarm and status switch signals of the unit to the main circuit breaker control system. This ensures that it is not possible to start the machine before the purge is complete and the machine enclosure is pressurized.

5.7 Running the machine the first time

After a successful first test start, the coupling between the driving and driven machine should be coupled, and the machine can be restarted.

5.7.1 Supervision during the first run

During running the machine the first time, it is verified that the machine functions as expected. The vibration level, the temperature of the windings and bearings, and other equipment are monitored frequently. If the machine functions as expected, the machine can be left running for a longer time.

Check the operating load of the machine by comparing the load current with the value given on the rating plate of the machine.

Record the temperature readings given by the temperature detectors placed in the windings and possibly in the bearings. Check the temperatures frequently to ensure that they remain below the limits. Continuous temperature monitoring is recommended.

NOTE: If resistance temperature detector (RTD, Pt-100) or equivalent is not available, the surface temperature of the bearing area shall, if possible, be measured. The bearing temperature is approximately 10°C (20°F) higher than the surface temperature.

In case of any deviations from expected normal operation, e.g. elevated temperatures, noise or vibration, shut down the machine, and find the reason for the deviations. If necessary, consult the manufacturer of the machine.

NOTE: Do not disengage any protective devices during running of the machine, or during search for a reason for unexpected function of the machine.

5.7.2 Checks during running of the machine

During the first days of running, it is important to keep a close surveillance of the machine in case of any changes in vibration or temperature levels or abnormal sounds should occur.

5.7.3 Bearings

The rotating electrical machines manufactured by ABB are equipped with either rolling or sleeve bearings.

*****Following chapter for bearing type: Rolling bearing**

5.7.3.1 Machines with rolling bearings

In case of a newly installed machine or a machine, which has been out of service for more than 2 months, inject new grease into the bearings immediately after start-up. New grease must be injected when the machine is running, and is injected until old grease or excess new grease is discharged through the lubrication channel in the bottom of the bearing housing, see *Figure 5-1 Example of lubrication channel through bearing arrangement of horizontal machine*.

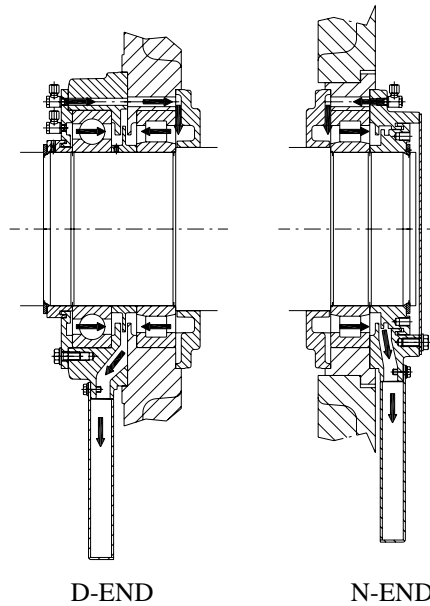

Figure 5-1 Example of lubrication channel through bearing arrangement of horizontal machine

NOTE: The re-lubrication interval will never be longer than 12 months.

The type of original grease used is found on the bearing plate on the machine. Acceptable types of grease can be found in *Chapter 7.5.3 Rolling bearings*.

The temperature of the bearings will initially increase because of the excess grease. After few hours, the excess grease will be discharged through the lubrication valve and the temperature of the bearing will return to normal running temperature.

If available, and after the machine has been running for several hours, measure the vibrations or SPM-values from the SPM-nipples, and record the values for future reference use.

*****Following chapter for bearing type: Sleeve bearing**

5.7.3.2 Machines with sleeve bearings

Verify that no rotating parts rub against any stationary parts. Verify through the oil sight glass that the oil level inside bearing is correct. The correct oil level is in the middle of the oil sight glass, but as long as the oil level is within the oil sight glass, the level is acceptable.

Check the temperature and the oil level of the bearings continuously in the beginning. This is particularly important for self-lubricating bearings. If the temperature of the bearing suddenly rises, the machine should be stopped immediately, and the reason for the temperature rise must be found before the machine is re-started. If no logical reason is found from the measurement equipment, it is recommended that the bearing is opened, and its condition verified. If the machine is under warranty, the manufacturing factory must always be contacted before any action is taken.

For self-lubricating bearings, the rotation of the oil ring is verified through the inspection window on top of the bearing. If the oil ring is not rotating, the machine must be stopped immediately, as a stopped oil ring will result in bearing failure.

For flood-lubricated machines, the oil supply pressure is adjusted with the pressure valve and orifice. The normal supply pressure is $125 \text{ kPa} \pm 25 \text{ kPa}$ ($18 \text{ psi} \pm 4 \text{ psi}$). This gives the right flow of oil to the bearing. Using higher supply pressure gives no additional benefit, but can cause bearing oil leakages. The rate of oil flow is also specified on the dimensional drawing.

NOTE: The lubrication system should be constructed so that the pressure inside the bearing is equal to the atmospheric (outside) pressure. Air pressure entering the bearing from either inlet or outlet oil pipes will cause bearing oil leakages.

5.7.4 Vibrations

For a comprehensive discussion on vibrations, see *Chapter 7.4.2 Vibration and noise*.

5.7.5 Temperature levels

The temperatures of the bearings, stator windings and cooling air should be checked when the machine is running.

The winding and bearing temperature may not reach a stable temperature until after several (4-8) hours, when running at full load.

The stator winding temperature depends on the load of the machine. If full load cannot be obtained during or soon after commissioning, the present load and temperature should be noted and included in the commissioning report.

Recommended settings for alarm and trip levels see main connection diagram and *Chapter 7.4.3.3 Evaluation*.

*****Following chapter for cooling type: Air-to-air and air-to-water**

5.7.6 Heat exchangers

Prior to start, check that the connections are tight and there is no leakage in the system. After running the machine for some time, the cooling system should be checked. Verify that the cooling fluid, where applicable, and air is circulating without any obstruction.

*****Following chapter for rotor type: Slip rings**

5.7.7 Slip rings

Check that the brushes on the slip rings are not sparking.

5.8 Shut down

The shutdown of the machine depends on the application, but main guidelines are:

- Reduce the load of the driven equipment, if applicable
- Open the main breaker
- Switch possible anti condensation heaters on, if not automatically done by switch gear

*****Following bullet for cooling type: Air-to-water, and water jacket**

- On water cooled machines, switch off the cooling water flow to avoid condensation inside the machine.

Chapter 6 Operation

6.1 General

To ensure trouble-free running a machine must be looked after and carefully supervised.

Always before starting up the machine ensure that:

- The bearings are greased or filled with oil to a correct level in accordance with the manufacturer's technical specifications and the dimensional drawing
- The cooling system is functioning
- The machine enclosure has been purged and is pressurized if applicable
- No maintenance is ongoing
- The personnel and equipment associated with the machine are ready to start up the machine.

For start-up procedure, see *Chapter 5.6.3 Starting*.

In case any deviations from expected normal operation are noticed, e.g. elevated temperatures, noise or vibration, shut down the machine, and find the reason for the deviations. If necessary, consult the manufacturer of the machine.

NOTE: The machine may have hot surfaces when running with load.

*****Following note for rotor type: Permanent magnet rotor**

NOTE: Overloading the machine may cause demagnetization of the permanent magnets as well as winding damages.

6.2 Normal operating conditions

The machines manufactured by ABB are individually designed to operate in normal operation conditions according to the IEC or NEMA standards, customer specifications and internal ABB standards.

The operation conditions, such as maximum ambient temperature and maximum operating height, are specified in the performance data sheet delivered as a part of the project documentation. The foundation shall be free from external vibration, and the surrounding air shall be free of dust, salt and corrosive gases or substances

NOTE: The safety precautions shown in *Safety Instructions* at the beginning of the manual must be observed at all times.

6.3 Number of starts

The number of allowed consecutive starts of direct on line supplied machines depends essentially on the load characteristics (torque curve vs. rotational speed, inertia), and on the machine type and design. Too many and/or too heavy starts cause abnormally high temperatures and stresses on the machine, thus accelerating the ageing of the machine and resulting in an abnormally short lifetime, or even a machine failure.

For information on the allowed consecutive or annual starts, please see the performance data sheet or consult the manufacturer. The load characteristics of the application are needed for determining the starting frequency. As a guideline, the maximum number of starts in a typical application is 1000 starts per year.

A counter system for controlling the number of starts should be used and maintenance intervals should be determined based on equivalent operating hours, see *Chapter 7.3 Maintenance program*.

NOTE: The safety precautions shown in the *Safety Instructions* at the beginning of the manual must be observed at all times.

6.4 Supervision

The operating personnel should inspect the machine at regular intervals. This means that they should listen, feel and smell the machine and its associated equipment in order to obtain a feeling for normal operating condition.

The object of the supervision inspection is to familiarize the personnel with the equipment. This is essential in order to detect and fix abnormal occurrences in time.

The difference between supervision and maintenance is rather diffuse. Normal supervision of operation includes logging of operating data such as load, temperatures and vibrations. This data is useful basis for maintenance and service.

- During the first period of operation (- 200 hours) supervision should be intensive. Temperatures of bearings and windings, load, current, cooling, lubrication and vibration shall be checked frequently
- During the following duty period (200 - 1000 hours), a check-up once a day is sufficient. A record of supervision inspections should be filed and saved for further reference. The time between inspections may be extended if the operation is continuous and stable.

For relevant check-lists, see *Appendix COMMISSIONING REPORT*.

6.4.1 Bearings

The bearing temperatures and lubrication should be monitored closely, see *Chapter 5.7.3 Bearings*.

6.4.2 Vibrations

The vibration levels of the driving-driven machine system should be monitored, see *Chapter 7.4.3 Vibrations*.

6.4.3 Temperatures

The temperatures of the bearings, stator windings and cooling air should be checked when the machine is running, see *Chapter 5.7.5 Temperature levels*.

*****Following chapter for cooling type: Air-to-air, and air-to-water**

6.4.4 Heat exchanger

Check that the connections are tight and there is no leakage in the system. Verify that the cooling fluid, where applicable, and air is circulating without any obstruction.

*****Following chapter for rotor type: Slip rings**

6.4.5 Slip ring unit

Follow the wear of the carbon brushes and change them before the wear limit is reached. Verify that the brushes are not sparking.

Ensure that the slip ring surfaces are smooth. If not, the slip rings must be smoothed on a lathe. Under ideal conditions, an even layer of brown patina will form on the slip rings during the first few hours of operation.

Check the tightness of the slip ring housing. Water, grease, oil, or dust should not be permitted to enter the housing.

6.5 Follow-up

The follow-up of operation includes logging of operating data such as load, temperatures and vibrations. This data is useful basis for maintenance and service.

6.6 Shut down

When the machine is not in operation, anti-condensation heaters have to be switched on where applicable. This is to avoid condensation effect inside the machine.

*****Following paragraph for cooling method: Air-to-water, and water jacket**

For machines with water-cooling, the cooling water supply must be switched off in order to avoid condensation inside the machine.

NOTE: Voltage may be connected to the terminal box for heating element.

Chapter 7 Maintenance

7.1 Preventive maintenance

A rotating electrical machine often forms an important part of a larger installation and if it is supervised and maintained properly, it will be reliable in operation and guarantee a normal lifetime.

The purpose of maintenance is therefore to:

- Secure that the machine will function reliably without any unforeseen actions or interventions
- Estimate and plan service actions in order to minimize down time.

The difference between supervision and maintenance is rather diffuse. Normal supervision of operation and maintenance includes logging of operating data such as load, temperatures, vibrations, as well as verification of the lubrication, and measurement of the insulation resistances.

After commissioning or maintenance, the supervision should be intensive. Temperature of bearings and windings, load, current, cooling, lubrication and vibration shall be checked frequently.

This chapter presents recommendations regarding maintenance program, and work instructions how to conduct common maintenance tasks. These instructions and recommendations should be read carefully and be used as a basis when planning the maintenance program. Note that the maintenance recommendations presented in this chapter represent a minimum level of maintenance. By intensifying maintenance and supervision activities, the reliability of the machine and the long-term availability will increase.

The data obtained during supervision and maintenance is useful for estimating and planning additional service. In case some of this data indicates something out of the ordinary, the trouble shooting guides in *Chapter 8 Trouble Shooting*, will aid in locating the reason for the trouble.

ABB recommends the use of experts in the creating maintenance programs, as well as in performing the actual maintenance and possible trouble shooting. The ABB After Sales organization is happy to assist in these issues. The ABB After Sales contact information can be found in *Chapter 9.1.5 After Sales contact information*.

An essential part of the preventative maintenance is to have a selection of suitable spare parts available. The best way to have access to critical spare parts is to keep them on stock. Ready-made spare part packages can be obtained from the ABB After Sales, see *Chapter 9.1.2 Spare Parts*.

7.2 Safety precautions

Before working on any electrical equipment, general electrical safety precautions are to be taken into account, and local regulations are to be respected in order to prevent personnel injury. This should be made according to instructions of the security personnel.

Personnel performing maintenance on electrical equipment and installations must be highly qualified. The personnel must be trained in, and familiar with, the specific maintenance procedures and tests required for rotating electrical machines.

*****Following three paragraphs for protection type: All machines for hazardous areas**

Machines for hazardous areas are specially designed to comply with official regulations concerning the risk of explosion. If improperly used, badly connected, or altered, no matter how minor, their reliability could be in doubt.

Standards relating to the connection and use of electrical apparatus in hazardous areas must be taken into consideration, especially national standards for installation (see standards: IEC 60079-14, IEC 6000-17 and IEC 6007-19). Only trained personnel familiar with these standards should handle this type of apparatus.

Disconnect and lock out before working on the machine or the driven equipment. Ensure that no explosive atmosphere is present while the work is in progress.

For general safety instructions, see *Safety Instructions* at the beginning of the manual.

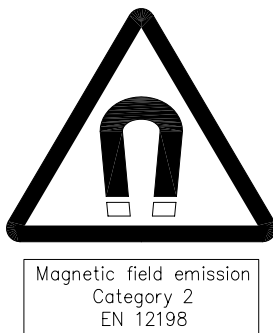
*****Following note for rotor type: Permanent magnet rotor**

NOTE: The permanent magnet synchronous machine produces voltage when the shaft is rotating. Prevent rotation of the shaft before opening the terminal box. Do not open or touch the unprotected terminals while the shaft of the machine is rotating. Follow the *Safety Instructions* at the beginning of the manual.

*****Following note for application type: Variable speed drive**

NOTE: The terminals of a machine with frequency converter supply may be energized even when the machine is at standstill.

7.3 Maintenance program

This chapter presents a recommended maintenance program for ABB machines. This maintenance program is of a general nature, and should be considered as a minimum level of maintenance. Maintenance should be intensified when local conditions are demanding or very high reliability is required. It should also be noted that even when following this maintenance program, normal supervision and observation of the machine's condition is required.

Please note that even though the maintenance programs below have been customized to match the machine, it might contain references to accessories not available on all machines.

The maintenance program is based on four levels of maintenance, which rotate according to operating hours. The amount of work and down time vary, so that level 1 includes mainly quick visual inspections and level 4 more demanding measurements and replacements. More information about the spare part packages suitable for these maintenances can be found in *Chapter 9.2 Spare parts for rotating electrical machines*. The recommended maintenance interval can be seen in *Table 7-1 Maintenance intervals*. The operation hour recommendation in this chapter is given as equivalent operating hours (Eq. h), that can be counted by the following formula:

*****Following paragraph for application type: Variable speed drive**

Equivalent operating hours (Eq. h) = Actual operating hours

*****Following paragraph for application type: Constant speed drive**

Equivalent operating hours (Eq. h) = Actual operating hours + Number of starts x 20

Level 1 (L1)

Level 1 or L1 maintenance consists of visual inspections and light maintenance. The purpose of this maintenance is to do a quick check whether problems are beginning to develop before they cause failures and unscheduled maintenance breaks. It gives also suggestions what maintenance issues must be performed in the next larger overhaul.

The maintenance can be estimated to last approximately 4 - 8 hours, depending on the type and installation of the machine and the depth of the inspections. Tools for this maintenance include normal servicing tools i.e. wrenches and screw drives. The preparations consist of opening the inspection covers. It is recommended that at least the Operational spare part package is available when commencing this maintenance. The packages are shown in *Chapter 9.2.5 Typical recommended spare parts in different sets*.

The first Level 1 maintenance should be performed after 4 000 equivalent operating hours or six months after commissioning. Subsequently the L1 maintenance should be performed yearly halfway between Level 2 maintenances, see *Table 7-1 Maintenance intervals*.

Level 2 (L2)

Level 2 or L2 maintenance consists mainly of inspections and tests and small maintenance tasks. The purpose of this maintenance is to find out whether there are problems in the operation of the machine and to do small repairs to ensure uninterrupted operation.

The maintenance can be estimated to last approximately 8 - 16 hours, depending on the type and installation of the machine and the amount of servicing to be done. Tools for this maintenance include normal servicing tools, multi meter, torque wrench and insulation resistance tester. The preparations consist of opening the inspection covers and bearings if necessary. Spare parts suitable for this level of maintenance are included in the Operational spare part package. The packages are shown in *Chapter 9.2.5 Typical recommended spare parts in different sets*

The first Level 2 maintenance should be performed after 8 000 equivalent operating hours or one year after commissioning. Subsequently the L2 maintenance should be performed yearly or after every 8 000 equivalent operating hours, see *Table 7-1 Maintenance intervals*.

Level 3 (L3)

Level 3 or L3 maintenance consists of performing extensive inspections, tests and larger maintenance tasks that have come up during L1 and L2 maintenances. The purpose of this maintenance is to repair encountered problems and replace parts subjected to wear.

The maintenance can be estimated to last approximately 16 - 40 hours, depending on the type and installation of the machine and the amount of repairs and replacements to be done. Tools for this maintenance include the same tools as for L2 and in addition an endoscope and an oscilloscope. The preparations consist of opening the inspection covers, the bearings and the water cooler, if applicable. Spare parts suitable for this level of maintenance are included in the Recommended spare parts package. The packages are shown in *Chapter 9.2.5 Typical recommended spare parts in different sets*.

The Level 3 maintenance should be performed after every 24 000 equivalent operating hours or at a three to five year interval. When L3 maintenance is conducted it replaces the L1 or L2 maintenance otherwise scheduled, and it leaves their rotation unaffected, see *Table 7-1 Maintenance intervals*.

Level 4 (L4)

Level 4 or L4 maintenance consists of performing extensive inspections and maintenance tasks. The purpose of this maintenance is to restore the machine into a reliable operating condition.

The maintenance can be estimated to last approximately 40 - 80 hours, depending mostly on the condition of the machine and the needed reconditioning actions. Tools for this maintenance include the same tools as for L3, and in addition, the rotor removal equipment. The preparations consist of opening the inspection covers, bearings and water cooler, if applicable, and the removal of rotor.

The amount of spare parts required for this level of maintenance needs to be determined before the maintenance. At least the Recommended spare part is needed. Spare parts included in the capital spare part package would ensure a fast and successful execution of this maintenance.

The Level 4 maintenance should be performed after every 80 000 equivalent operating hour. When a L4 maintenance is conducted it replaces the L1, L2 or L3 maintenance otherwise scheduled, and it leaves their rotation unaffected, see *Table 7-1 Maintenance intervals*.

7.3.1 Recommended maintenance program

Abbreviation used in maintenance program:

- V = Visual checking
- C = Cleaning
- D = Disassembling and assembling
- R = Reconditioning or replacement
- T = Testing and measurement.

Not all options are applicable for all machines.

Table 7-1. Maintenance intervals

Maintenance object	MAINTENANCE INTERVAL				Check / Test
	In equivalent operating hours or time period, which ever comes first				
	L1	L2	L3	L4	
	4 000 Eq. h 12 000 Eq. h 20 000 Eq. h 28 000 Eq. h	8 000 Eq. h 16 000 Eq. h	24 000 Eq.h	80 000 Eq.h	
	½ year	Annual	3-5 years	Overhaul	

7.3.1.1 General construction

Maintenance object	L1	L2	L3	L4	Check / Test
Machine operation	V / T	V / T	V / T	V / T	Starting, shut down, vibration measurement, no-load point
Mounting and foundation	V	V / T	V / T	V / T / D	Cracks, rust, alignment
Exterior	V	V	V	V	Rust, leakage, condition
Fastenings	V	V / T	V / T	V / T	Tightness of all fastenings
Anchor bolts	V	V	V / T	V / T	Fastening, condition

7.3.1.2 Main supply connection

Maintenance object	L1	L2	L3	L4	Check / Test
High voltage cabling	V	V / T	V / T	V / T / D	Wear, fastening
High voltage connections	V	V / T	V / T	V / T / D	Oxidation, fastening
Terminal box accessories, i.e. surge capacitors, arrestors and current transformers	V	V	V	V	General condition
Cable transits	V	V	V	V	Condition of cables entering the machine and inside the machine

7.3.1.3 Stator and rotor

Maintenance object	L1	L2	L3	L4	Check / Test
Stator core	V	V	V	V / C	Fixing, cracks, welds
Stator winding insulation	V	V / T	V / T / C	V / T / C	Wear, cleanliness, insulation resistance, turn insulation test, (high voltage test)
Stator coil over hangs	V	V	V	V	Insulation damages
Stator coil supports	V	V	V	V	Insulation damages
Stator slot wedges	V	V	V	V	Movement, tightness
Stator terminal bars	V	V	V	V	Fixing, insulation
Instrumentation	V	V	V	V	Condition of cables and cable ties
Rotor winding insulation	V	V / T	V / T / C	V / T / C	Wear, cleanliness, insulation resistance
Rotor balancing weights	V	V	V	V	Movement
Shaft	V	V	V	V	Crack, corrosion
Connections in rotor	V	V	V / T	V / T	Fixing, general condition
Earthing brushes	V	V	V	V	Operation and general condition

NOTE: It is not recommended that totally enclosed machines are dismantled and inspected internally more often than every 3-5 years (L3).

7.3.1.4 Auxiliaries

Maintenance object	L1	L2	L3	L4	Check / Test
Pt-100 elements (stator, cooling air, bearing)	V	V / T	V / T	V / T	Resistance
Anticondensation heaters	V	V / T	V / T	V / T	Operation, insulation resistance
Encoders	V	V	V / T	V / T	Operation, general condition, alignment
Auxiliary terminal boxes	V	V / T	V / T	V / T	General condition, terminals, wiring condition

***Following table for rotor type: Slip rings

7.3.1.5 Slip ring unit

Maintenance object	L1	L2	L3	L4	Check / Test
Assembly	V	V / C	V / C	V / C	Mounting, insulation
Brush holders	v	V / T	V / T	V / T	Alignment
Brushes	V	V / T	V / T	V / T	Arching, clearance
Slip ring cabling	V	V	V	V	Wear, arching
Slip rings	V / T	V / T	V / T	V / T	Wear, roundness, patina
Brush gear	V	V / T	V / T	V / T	Insulation resistance
Pt-100 elements	V	V / T	V / T	V / T	Resistance
Anticondensation heaters	V	V / T	V / T	V / T	Operation, insulation resistance
Encoders	V	V	V / t	V / T	Operation, general condition, alignment
Auxiliary terminal boxes	V	V / T	V / T	V / T	General condition, terminals, wiring condition

7.3.1.6 Lubrication system and bearings

***Following table for bearing type: Rolling bearing

Maintenance object	L1	L2	L3	L4	Check / Test
Bearing during operation	T	T	T / R	T / R	General condition, extra noise, vibration
Waste grease	V	V / C	V / C	V / C	Condition, purging
Re-greasing	V	V / R	V / R	V / R	According to bearing plate
Seals	V	V / D	V / D	V / D	Leakage
Bearing insulation	V / C	V / C	V / C / T	V / C / T	Endshield cleanliness, insulation resistance

***Following table for bearing type: Sleeve bearing

Maintenance object	L1	L2	L3	L4	Check / Test
Bearing assembly	V	V / T	V / T	V / T	Fixing, general condition
Bearing shells	V	V	V / T / D	V / T / D	General condition, wear
Seals and gaskets	V	V	V / T / D	V / T / D	Leakage
Bearing insulation	V	V / T	V / T / D	V / T / D	Condition, insulation resistance
Lubrication piping	V	V	V / T / D	V / T / D	Leakage, operation

Maintenance object	L1	L2	L3	L4	Check / Test
Lubrication oil	V / R	V / R	V / R	V / R	Quantity, quality, flow
Oil ring	V	V	V	V	Operation
Oil flow regulator	V	V / T	V / T	V / T / D	Operation
Oil tank	V	V / C	V / C	V / C	Cleanliness, leakage
Jack-up system	V	V / T	V / T	V / T	Operation
Oils cooler / heater	T	T	T	T	Oil temperature

7.3.1.7 Cooling system

*****Following table for cooling type: Open air**

Maintenance object	L1	L2	L3	L4	Check / Test
Fan(s)	V	V	V	V	Operation, condition
Filters	V / C	V / C	V / C / R	V / C / R	Cleanliness, operation
Air ways	V	V / C	V / C	V / C	Cleanliness, operation

*****Following table for cooling type: Air-to-air**

Maintenance object	L1	L2	L3	L4	Check / Test
Fan(s)	V	V	V	V	Operation, condition
Tubes	V	V / C	V / C	V / C	Cleanliness, operation
Ducts	V	V / C	V / C	V / C	Cleanliness, operation
Plate fins	V	V / C	V / C	V / C	General condition
Vibration dampers	V	V	V	V	Condition and profile

*****Following table for cooling type: Air-to-water**

Maintenance object	L1	L2	L3	L4	Check / Test
Heat exchanger	V	V	V	V	Leakage, operation, pressure test
Fan	V	V	V	V	Operation, condition
Tubes	V	V / C	V / C	V / C	Cleanliness, corrosion
Ducts	V	V / C	V / C	V / C	Cleanliness, operation
End cases	V	V / C	V / C	V / C	Leakage, condition
Seals and gaskets	V	V / C	V / C	V / C	Leakage, condition

Maintenance object	L1	L2	L3	L4	Check / Test
Plate fins	V	V / C	V / C	V / C	General condition
Vibration dampers	V	V	V	V	Condition and profile
Protective anodes			V / C	V / C	Condition, activity
Water flow regulator	V / T	V / T	V / T	V / T	Operation

7.4 Maintenance of general constructions

To ensure a long life span for the general construction of the machine, the machine exterior should be kept clean and should periodically be inspected for rust, leaks and other defects. Dirt on the machine exterior exposes the frame to corrosion and can affect the cooling of the machine.

7.4.1 The tightness of fastenings

The tightness of all fastenings should be verified regularly. Special focus should be given to the grouting, the anchor bolts and the rotor parts, which must remain correctly tightened at all times. Loose fastening in these parts can lead to sudden and severe damage to the entire machine.

General values for tightening torques are presented in *Table 7-2 General tightening torques*.

Table 7-2. General tightening torques

Size	Tightening torque in Nm (pound-feet) Property class 8.8 for bolts			
	Oiled [Nm]	Oiled [pound feet]	Dry [Nm]	Dry [pound feet]
M 4	2.7	2.0	3.0	2.2
M 5	5.0	3.7	5.5	4.1
M 6	9	6.6	9.5	7.0
M 8	22	12	24	18
M 10	44	32	46	34
M 12	75	55	80	59
M 14	120	88	130	96
M 16	180	130	200	150
M 20	360	270	390	290
M 24	610	450	660	490
M 27	900	660	980	720
M 30	1200	890	1300	960
M 36	2100	1500	2300	1700
M 39	2800	2100	3000	2200
M 42	3400	2500	3600	2700
M 48	5200	3800	5600	4100

NOTE: The values in *Table 7-2 General tightening torques* are general, and do not apply to various items, such as diodes, support insulators, bearings, cable terminals or pole fastenings, bus bar terminals, surge arrestors, capacitors, current transformers, rectifier and thyristor bridges, or if some other value is given elsewhere in this manual.

7.4.2 Vibration and noise

High or increasing vibration levels indicate changes in the machine's condition. Normal levels vary greatly depending on the application, type and foundation of the machine. The vibration measurements and levels are discussed in detail in *Chapter 7.4.3 Vibrations*. Some typical reasons that might cause high noise or vibration levels are:

- Alignment, see *Chapter 3 Installation and Alignment*
- Bearing wear or damage
- Vibration from connected machinery, see *Chapter 7.4.3 Vibrations*

- Loose fastenings or anchor bolts, see *Chapter 3 Installation and Alignment*
- Rotor imbalance
- Coupling.

7.4.3 Vibrations

The following instructions are part of the following two ISO standards: ISO 10816-3:1998 Mechanical vibration - Evaluation of machine vibration by measurements on non-rotating parts: Part 3: Industrial machines with nominal power above 15 kW and nominal speeds between 120 r/min and 15 000 r/min when measured in situ and ISO 8528-9:1995 Reciprocating internal combustion engine driven alternating current generating sets: Part 9: Measurement and evaluation of mechanical vibrations.

7.4.3.1 Measurement procedures and operational conditions

Measurement equipment

The measurement equipment shall be capable of measuring broad-band r.m.s. vibration with flat response over a frequency range of at least 10 Hz to 1 000 Hz, in accordance with the requirements of ISO 2954. Depending on the vibration criteria, this may require measurements of displacement or velocity or combinations of these (see ISO 10816-1). However, for machines with speeds approaching or below 600 r/min, the lower limit of the flat response frequency range shall not be greater than 2 Hz.

Measurement locations

Measurements will usually be taken on exposed parts of the machine that are normally accessible. Care shall be taken to ensure that measurements reasonably represent the vibration of the bearing housing and do not include any local resonances or amplification. The locations and directions of vibration measurements shall be such that they provide adequate sensitivity to the machine dynamic forces. Typically, this will require two orthogonal radial measurement locations on each bearing cap or pedestal, as shown in *Figure 7-1 Measuring points*. The transducers may be placed at any angular position on the bearing housings or pedestals. Vertical and horizontal directions are usually preferred for horizontally mounted machines. For vertical or inclined machines, the location that gives the maximum vibration reading, usually in the direction of the elastic axis, shall be one of those used. In some cases it may be recommended to measure also in the axial direction. The specific locations and directions shall be recorded with the measurement.

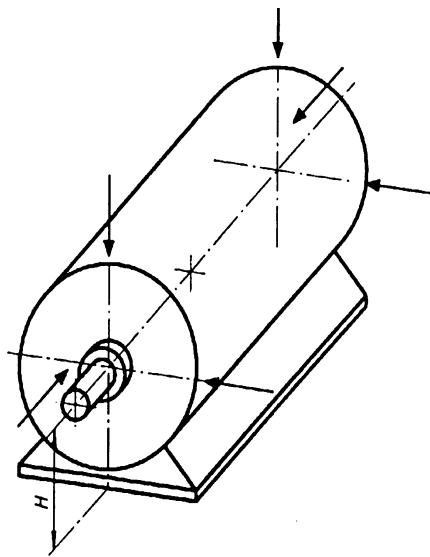

Figure 7-1 Measuring points

7.4.3.2 Classification according to support flexibility

Two conditions are used to classify the support assembly flexibility in specified directions:

- rigid supports
- flexible supports

These support conditions are determined by the relationship between the machine and foundation flexibilities. If the lowest natural frequency of the combined machine and support system in the direction of measurement is higher than its main excitation frequency (this is in most cases the rotational frequency) by at least 25 %, then the support system may be considered rigid in that direction. All other support systems may be considered flexible.

7.4.3.3 Evaluation

ISO 10816-1 provides a general description of the two evaluation criteria used to assess vibration severity on various classes of machines. One criterion considers the magnitude of observed broad-band vibration; the second considers changes in magnitude, irrespective of whether they are increases or decreases.

Evaluation zones

The following evaluation zones are defined to permit a qualitative assessment of the vibration of a given machine and provide guidelines on possible actions.

Zone A: The vibration of newly commissioned machines would normally fall within this zone.

Zone B: Machines with vibration within this zone are normally considered acceptable for unrestricted long-term operation.

Zone C: Machines with vibration within this zone are normally considered unsatisfactory for long-term continuous operation. Generally, the machine may be operated for a limited period in this condition until a suitable opportunity arises for remedial action.

Zone D: Vibration values within this zone are normally considered to be of sufficient severity to cause damage to the machine.

Operational limits

For long-term operation, it is common practice to establish operational vibration limits. These limits take the form of ALARMS and TRIPS.

Setting of ALARMS

The ALARM values may vary considerably, up or down, for different machines. The values chosen will normally be set relative to a baseline value determined from experience for the measurement position or direction for that particular machine.

It is recommended that the ALARM value should be set higher than the baseline by an amount equal to 25 % of the upper limit for zone B. If the baseline is low, the ALARM may be below zone C.

Setting of TRIPS

The TRIP values will generally relate to the mechanical integrity of the machine and be dependent on any specific design features which have been introduced to enable the machine to withstand abnormal dynamic forces. The values used will, therefore, generally be the same for all machines of similar design and would not normally be related to the steady-state baseline value used for setting ALARMS.

Table 7-3. Classification of vibration severity zones for large machines with rated power above 300 kW and not more than 50 MW; electrical machines with shaft height H/315 mm or higher

Support class	Zone boundary	R.m.s. velocity [mm/s]
Rigid	A/B	2.3
	B/C	4.5
	C/D	7.1
Flexible	A/B	3.5
	B/C	7.1
	C/D	11.0

7.5 Maintenance of bearings and lubrication system

This chapter covers the most important maintenance tasks in the bearings and in the lubrication system.

*****Following chapters for bearing type: Sleeve bearing**

7.5.1 Sleeve bearings

In normal operating conditions, sleeve bearings require little maintenance. To ensure reliable operation, the oil level and the amount of oil leakage should be regularly checked.

7.5.1.1 Oil level

The oil level of a self-lubricated sleeve bearing needs to be checked regularly. The correct oil level is in the middle of the oil sight glass, but as long as the oil level is within the oil sight glass, the level is acceptable.

If necessary, refill with suitable lubricant, see *Chapter 7.5.2.4 Oil qualities*.

The correct oil level of a flood-lubricated sleeve bearing is the same as for a self-lubricated bearing. In flood-lubricated bearings, the oil sight glass might be exchanged for an oil outlet flange.

7.5.1.2 Bearing temperature

The bearing temperatures are measured by Pt-100 resistance temperature detectors. Since a temperature rise above the alarm limit can be caused either by increased losses in the bearing, or by decreased cooling capacity, it often indicates a problem somewhere in the machine or in the lubrication system, and should therefore be closely monitored.

The reasons for abnormal bearing temperature vary, but for some possible reason see *Chapter 7.5.2 Lubrication of sleeve bearings* or *Chapter 8.1.2 Lubrication system and bearings*. If the temperature rise is followed by an increase in vibration levels, the problem might also be related to the machine's alignment, see *Chapter 3 Installation and Alignment* or to damage in the bearing shells in which case the bearing needs to be dismantled and checked.

7.5.2 Lubrication of sleeve bearings

The machines are equipped with sleeve bearings with a very long service life provided that the lubrication functions continuously and that the oil type and quality are as per ABB recommendations, and that the oil change instructions are followed.

7.5.2.1 Lubrication oil temperature

The correct lubrication oil temperature is essential in keeping the bearing at the correct operating temperature, and in ensuring sufficient lubrication effect and the correct viscosity of the lubrication oil. For machines equipped with oil supply, the poor operation of oil cooler or heater and incorrect oil flow can cause oil temperature problems. For all bearings, the correct oil quality and quantity need to be checked if temperature problems appear. For more information, see *Chapter 7.5.2.3 Recommended control values for the lubricating oil* and *Chapter 7.5.2.4 Oil qualities*.

NOTE: The minimum ambient temperature in starting (without oil heater) is 0°C (32° F).

7.5.2.2 Control of the lubricant

During the first year of operation, it is advisable to take samples of the lubricating oil after about 1000, 2000 and 4000 operating hours. The sample should be sent to the oil supplier for analysis. Based on the results it is possible to determine a suitable oil change interval.

After the first oil change, the oil may be analyzed at about the middle and the end of the oil change interval.

7.5.2.3 Recommended control values for the lubricating oil

The lubricating oil should be verified regarding the following aspects:

- Check the oil visually with respect to color, turbidity and deposits in a test bottle. The oil should be clear or negligibly turbid. The turbidity may not be caused by water
- The water content must not exceed 0.2%
- The original viscosity must be maintained within a tolerance of $\pm 15\%$
- The oil should be free from debris, and its cleanliness according to ISO 4406 class 18/15, or NAS 1638 class 9
- The quantity of metal impurities should be less than 100 PPM. An increasing trend of the value means that the bearing is wearing
- The total acid number (TAN) should not exceed 1 mg KOH per gram of oil. Please note that the TAN value is not the same as the TBN (total base number) value
- Smell the oil. Strong acid or burnt smell is not acceptable.

An oil check should be performed a few days after the first test run of the machine, just before the first oil change, and subsequently as required. If the oil is changed just after the commissioning, it can be used again after removing wear particles by filtering or centrifuging.

In doubtful cases, an oil sample may be sent to the laboratory to determine viscosity, acid number, foaming tendency, etc.

7.5.2.4 Oil qualities

The bearings are designed for one of the oil qualities listed below.

The oils listed below include the following additives:

- Oxidation and rust inhibitor
- Anti-foaming agent
- Anti-wear additive.

NOTE: Verify the correct oil quality from the bearing plate and the dimension drawing.

	ISO VG 22 Viscosity 22 cSt at 40 °C	ISO VG 32 Viscosity 32 cSt at 40 °C	ISO VG 46 Viscosity 46 cSt at 40 °C	ISO VG 68 Viscosity 68 cSt at 40 °C	ISO VG 100 Viscosity 100 cSt at 40 °C
Environmentally Benign Oils:					
Aral	Vitam EHF 22	-	Vitam EHF 46	-	-
Mobil	-	EAL Hydraulic Oil 32	EAL Hydraulic Oil 46	-	-
Shell	-	Naturelle HF-E 32	Naturelle HF-E 46	Naturelle HF-E 68	-
Mineral Oils:					
Aral	Vitam GF 22	Vitam GF 32	Vitam GF 46	Vitam GF 68	Degol CL 100 T
BP	Energol CS 22	Energol CS 32	Energol CS 46	Energol CS 68	Energol CS 100
Castrol	Hyspin AWS 22	Hyspin AWS 32	Hyspin AWS 46	Hyspin AWS 68	Hyspin AWS 100
Chevron	Texaco Rando HDZ 22	Texaco Rando HDZ 32	Texaco Rando HDZ 46	Texaco Rando HDZ 68	Texaco Rando HDZ 100
Esso	Nuto H 22	Terrestic T 32	Terrestic T 46	Terrestic T 68	-
Klüber		LAMORA HLP 32	LAMORA HLP 46	LAMORA HLP 68	CRUCOLAN 100
Mobil	Velocite Oil No. 10	DTE Oil Light	DTE Oil Medium	DTE Oil Heavy Medium	DTE Oil Heavy
Shell	Tellus S 22	Tellus S 32	Tellus S 46	Tellus S 68	Tellus S 100
Total	Azolla ZS 22	Azolla ZS 32	Azolla ZS 46	Azolla ZS 68	Azolla ZS 100

7.5.2.5 Oil change schedule for mineral oils

For self-lubricated bearings cleaning intervals with oil changes of approximately 8000 operating hours are recommended and approx. 20000 operating hours for bearings with oil circulation systems.

Shorter oil change intervals may be necessary in case of frequent start-ups, high oil temperatures or excessively high contamination due to external influences.

The correct oil change interval can be found on the bearing plate and dimensional drawing, see *Chapter 2.1.2 Bearing plate*.

*****Following chapter for bearing type: Rolling bearing**

7.5.3 Rolling bearings

7.5.3.1 Bearing construction

In normal operating conditions, rolling bearings require little maintenance. To ensure reliable operation, the bearings should be regularly re-greased with high-quality rolling bearing grease.

7.5.3.2 Bearing plate

All machines are supplied with bearing plates attached to the machine frame. The bearing plates provide bearing information, such as:

- Bearing type
- Lubricant used
- Re-greasing interval, and
- Re-greasing amount.

For more details regarding the bearing plate, see *Chapter 2.1.2 Bearing plate*.

NOTE: It is essential that the information provided on the bearing plate is taken into account when using and maintaining the machine.

7.5.3.3 Re-greasing intervals

Rolling bearings of electrical machines need to be re-greased at regular intervals. The re-greasing interval is found on the bearing plate.

NOTE: Regardless of the re-greasing interval, the bearings need to be re-greased at least once per year.

The re-greasing intervals are calculated for an operating temperature of 70°C (160°F). If the operating temperature is lower or higher than the assumed, the re-grease interval has to be altered accordingly. Higher operating temperature decreases the re-greasing interval.

NOTE: An increase in the ambient temperature raises the temperature of the bearings correspondingly. The values for the re-greasing interval should be halved for every 15°C (30°F) increase in bearing temperature and may be once doubled for a 15°C (30°F) decrease in bearing temperature.

Re-greasing intervals for frequency converter drives

Higher speed operation, e.g. in frequency converter applications, or lower speed with heavy load will require shorter lubrication intervals or a special lubricant. Consult manufacturing ABB factory After Sales department in such cases.

NOTE: The constructional maximum speed of the machine must not be exceeded. The suitability of the bearings for high-speed operation must be checked.

7.5.3.4 Re-greasing

All rolling bearings of rotating electrical machines need to be re-greased, see *Chapter 7.5.3.3 Re-greasing intervals*. The re-greasing can be performed either manually or by means of an automatic system. In either case, it has to be verified that a suitable amount of the correct grease is entering the bearing at suitable intervals.

NOTE: Grease can cause skin irritation and eye inflammation. Follow all safety precautions specified by the grease manufacturer.

Manual re-greasing of the bearings

Machines suited for manual re-greasing are equipped with grease nipples. In order to prevent debris from entering the bearings, the grease nipples, as well as the surrounding area has to be cleaned thoroughly before re-greasing.

Manual re-greasing while the machine is running

Re-greasing while the machine is running:

- Verify that the grease to be used is suitable
- Clean the grease nipples and the area around them
- Verify that the lubrication channel is open, if equipped with a handle, open it.
- Press the specified amount and type of grease into the bearing
- Let the machine run 1-2 hours in order to ensure that all excess grease is forced out of the bearing. The bearing temperature may temporarily increase during this time
- If equipped with a handle, close it.

NOTE: Beware of all rotating parts during the re-greasing.

Manual re-greasing while the machine is at a standstill

Preferably, re-grease the machine while it is running. If this is not possible, or considered dangerous, the re-greasing has to be carried out while the machine is at a standstill. In this case:

- Verify that the grease to be used is suitable
- Stop the machine
- Clean the grease nipples and the area around them
- Verify that the lubrication channel is open, if equipped with a handle, open it.
- Press only half the amount of the specified type of grease into the bearing
- Run the machine for a few minutes at full speed
- Stop the machine
- After the machine has stopped, press the specified amount of the correct grease into the bearing
- Let the machine run 1-2 hours in order to ensure that all excess grease is forced out of the bearing. The bearing temperature may temporarily increase during this time
- If equipped with a handle, close it.

Automatic re-greasing

A variety of automatic re-lubrication systems is available on the market. However, ABB recommends only the use of electromechanical re-lubrication systems. The quality of the grease entering the bearing has to be checked at least once per year: the grease has to look and feel like new grease. Any separation of the base oil from the soap is not acceptable.

NOTE: If an automatic re-greasing system is used, double the amount of grease indicated on the bearing plate.

7.5.3.5 Bearing grease

It is essential to use grease of good quality and with the correct base soap. This will ensure a long and trouble free lifetime of the bearings.

Grease used for re-greasing should have the following properties:

- Be special rolling bearing grease
- Be of good quality with a lithium complex soap, and with mineral-, or PAO-oil
- Have a base oil viscosity of 100 to 160 cSt at 40°C (105°F)
- Have a consistency NLGI grade between 1.5 and 3. For vertically or in hot conditions mounted machines, NLGI grade 2 or 3 is recommended
- Have a continuous temperature range between -30°C (-20°F) and at least +120°C (250°F).

Grease with the correct properties is available from all major lubricant manufacturers. If the make of grease is changed and compatibility is uncertain, consult the manufacturing ABB factory, see *Chapter 9.1.5 After Sales contact information*.

NOTE: Different makes of grease must not be mixed, unless the compatibility has been verified.

NOTE: Grease additives are recommended. However, a written guarantee should be obtained from the lubricant manufacturer stating that the additives do not damage the bearings or the properties of the grease in the field of the operating temperature. This is especially important for EP additives.

NOTE: Lubricants containing EP admixtures are not recommended.

Recommended rolling bearing grease

ABB recommends any of the following high performance greases to be used:

- Esso Unirex N2, N3 (lithium complex base)
- Mobilith SHC 100 (lithium complex base)
- Shell Albida EMS 2 (lithium complex base)
- Klüber Klüberplex BEM 41-132
- Lubcon Turmogrease Li 802 EP
- Total Multiplex S 2 A
- Fag Arcanol Temp 110

Re-greasing intervals for greases fulfilling the required properties other than the ones mentioned above should be halved.

Rolling bearing grease for extreme temperatures

If the bearing operating temperature is above 100°C (210°F), please consult the manufacturing ABB factory for suitable greases.

7.5.3.6 Bearing maintenance

The lifetime of the bearings is likely to be shorter than the lifetime of the electrical machine. Therefore, the bearings will have to be changed periodically.

The maintenance of rolling bearings requires special care, tools and arrangements as to ensure a long lifetime of newly fitted bearings.

During bearing maintenance, ensure that:

- No dirt or foreign debris is allowed to enter the bearings at any time during the maintenance
- The bearings are washed, dried and pre-greased with suitable and high quality rolling bearing grease before assembly
- The disassembly and mounting of the bearings does not damage the bearings. The bearings must be removed by using pullers and fitted by heating, or using special tools for the purpose.

If there is a need to change bearings, please contact ABB After Sales. See After Sales contact information in *Chapter 9.1.5 After Sales contact information*.

7.5.4 Bearing insulation and bearing insulation resistance check

The bearing insulation resistance check is a maintenance operation made primarily in the factory during the final assembly and testing. It should also be made during all comprehensive overhauls of the machine. Good insulation is necessary in order to eliminate the possibility of circulating bearing currents, which might be induced by shaft voltages. The insulation of the non-drive end bearing cuts the path of the bearing current and thus eliminates the risk of bearing damages due to bearing currents.

Both the shaft ends should not be insulated from the frame, as an electrically floating shaft would have an unknown electrical potential compared to the surroundings and would, therefore, be a potential source of damage. However, to make the testing of the non-drive end bearing insulation easier, the drive end bearing is also often insulated. This insulation is short-circuited by an earthing cable during normal operation; see *Figure 7-2 D-end bearing earthing cable*.

NOTE: Not all machines are equipped with insulated bearings.

NOTE: Machines with insulated bearings have a sticker indicating the insulated bearing.

7.5.4.1 Procedure

For machines with an insulated drive end bearing, the short-circuit earthing cable in the drive end bearing must be removed prior to commencing the non-drive end bearing insulation resistance test. If the drive end bearing is not insulated, it is required to perform the non-drive

end bearing insulation resistance test, to remove the drive-end bearing shells or the bearing shield and to lift the shaft. This ensures that there is no electrical contact between the shaft and any other part, for example, frame or bearing housing.

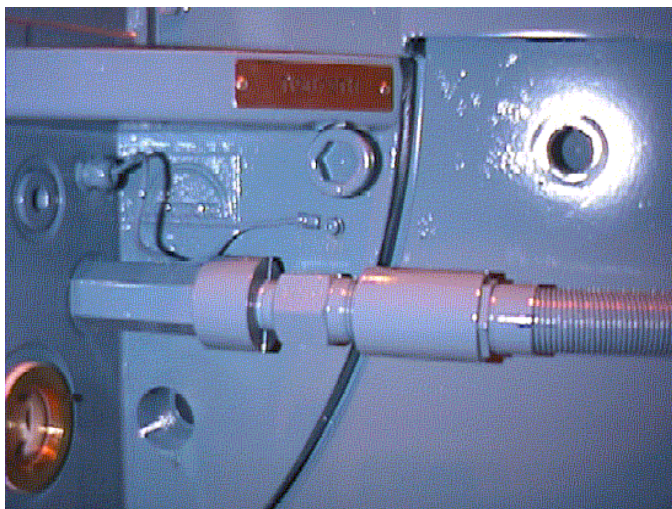

Figure 7-2 D-end bearing earthing cable

For all machines any optional shaft earthing brush, rotor earth fault brush and coupling (if it is made out of conductive material) must be removed. Measure the insulation resistance from the shaft to earth using no more than 100 VDC, see *Figure 7-3 Measuring the insulation resistance of a sleeve bearing* and *Figure 7-4 Measuring the insulation resistance of a roller bearing*. The measuring points over the bearing insulation are circled in the figures.

The insulation resistance is acceptable if the resistance value is more than 10 k Ω .



Figure 7-3 Measuring the insulation resistance of a sleeve bearing



Figure 7-4 Measuring the insulation resistance of a roller bearing

*****Following chapter for bearing type: Roller bearing**

7.5.4.2 Cleanliness of bearing insulation

The bearing insulations are installed in the end shields. To avoid decrease of the insulation resistance caused by foreign agents (salt, dirt) building up on the insulation surface, the cleanliness of the bearing insulation and the end shield surfaces around it should be checked regularly and cleaned if necessary. See *Figure 7-5 Bearing insulation and end shield surfaces* for areas that should be checked regularly and kept clean. The areas are marked with a circle and the bearing insulation is pointed out by an arrow in the figure.

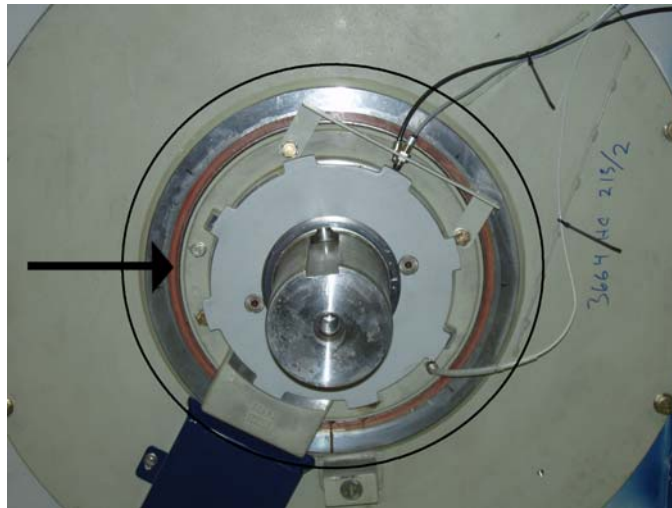

Figure 7-5 Bearing insulation and end shield surfaces

7.6 Maintenance of stator and rotor windings

The windings of rotating electrical machines are subjected to electrical, mechanical and thermal stresses. The windings and insulation gradually age and deteriorate due to these stresses. Therefore, the service life of the machine often depends on the insulation durability.

Many processes leading to damages can be prevented or at least slowed down with appropriate maintenance and regular testing. This chapter offers a general description on how to perform basic maintenance and tests.

In many countries, ABB Service offers complete service maintenance packages, which include comprehensive testing.

Before conducting any maintenance work on the electrical windings, general electrical safety precautions are to be taken and local regulations are to be respected in order to prevent personnel accidents. See *Chapter 7.2 Safety precautions* for more information.

Independent test and maintenance instructions can also be found in the following international standards:

1. IEEE Std. 43-2000, IEEE Recommended Practice for Testing Insulation Resistance of Rotating Machines
2. IEEE Std. 432-1992, IEEE Guide for Insulation Maintenance for Rotating Electrical Machinery (5 hp to Less Than 10 000 hp)

7.6.1 Particular safety instructions for winding maintenance

Some of the hazardous works of the winding maintenance include:

- Handling of hazardous solvents, varnishes, and resins. Hazardous substances are required for cleaning and re-varnishing windings. These substances can be dangerous if inhaled, swallowed or in any contact with skin or other organs. Seek proper medical care if an accident occurs
- Dealing with flammable solvents and varnishes. Handling and use of these substances should always be by authorized personnel and proper safety procedures must be followed
- Testing at high voltage (HV). High-voltage tests should only be conducted by authorized personnel and proper safety procedures must be followed.

Dangerous substances used in winding maintenance are:

- White spirit: solvent
- 1.1.1-trichloroethane: solvent
- Finishing varnish: solvent and resin
- Adhesive resin: epoxy resin.

NOTE: There are special instructions for handling dangerous substances during maintenance work. These instructions must be followed.

Some general safety measures during winding maintenance are as follows:

- Avoid breathing air fumes: ensure proper air circulation at the work site or use respiration masks
- Wear safety gear such as glasses, shoes, hardhat and gloves and suitable protective clothing to protect the skin. One should always use protective creams

- Spray-varnish equipment, the frame of the machine, and the windings should be earthed during spray varnishing
- Take necessary precautions when working in pits and cramped places
- Only people trained to do high-voltage work can carry out a voltage test
- Do not smoke, eat, or drink at the work site.

For a test record for winding maintenance, see *Appendix COMMISSIONING REPORT*.

7.6.2 The timing of the maintenance

There are three main principles for timing the winding maintenance:

- Maintenance of the windings should be arranged according to other machine maintenance
- Maintenance should be performed only when necessary
- Important machines should be serviced more often than the less important ones. This also applies to windings that become contaminated rapidly and to heavy drives.

NOTE: As a thumb rule, an insulation resistance test should be made once a year. This should suffice for most machines in most operating conditions. Other tests should only be conducted if problems arise.

A maintenance program for the complete machine, including windings, is presented in *Chapter 7.3 Maintenance program*. This maintenance program however, should be adapted to the customer's particular circumstances, i.e. servicing of other machines and operating conditions as long as recommended servicing intervals are not exceeded.

7.6.3 The correct operating temperature

The correct temperature of the windings is ensured by keeping the exterior surfaces of the machine clean, by seeing to the correct operation of the cooling system and by monitoring the temperature of the coolant. If the coolant is too cold, water may condense inside the machine. This can wet the winding and deteriorate the insulation resistance.

*****Following paragraph for cooling type: Open air**

For air-cooled machines, it is important to monitor the cleanliness of the air filters. The cleaning and change interval of the air filters should be planned according to the local operating environment.

The stator operating temperatures must be monitored with resistance temperature detectors. Significant temperature differences among the detectors could be a sign of damage in the windings. Make sure that the changes are not caused by the drifting of the measuring channel.

7.6.4 Insulation resistance test

During general maintenance work and before the machine is started up for the first time or after a long period of standstill, the insulation resistance of stator and rotor windings must be measured.

The insulation resistance measurement provides information about the humidity and dirtiness of the insulation. Based upon this information, correct cleaning and drying actions can be determined.

For new machines with dry windings, the insulation resistance is very high. The resistance can, however, be extremely low if the machine has been subjected to incorrect transportation and storage conditions and humidity, or if the machine is operated incorrectly.

NOTE: Windings should be earthed briefly immediately after measurement in order to avoid risk of electric shock.

7.6.4.1 Conversion of measured insulation resistance values

In order to be able to compare measured insulation resistance values, the values are stated at 40°C. The actual measured value is therefore converted to a corresponding 40°C value with the help of the following diagram. The use of this diagram should be limited to temperatures fairly near to the standard value of 40°C, since large deviations from it could result in errors.

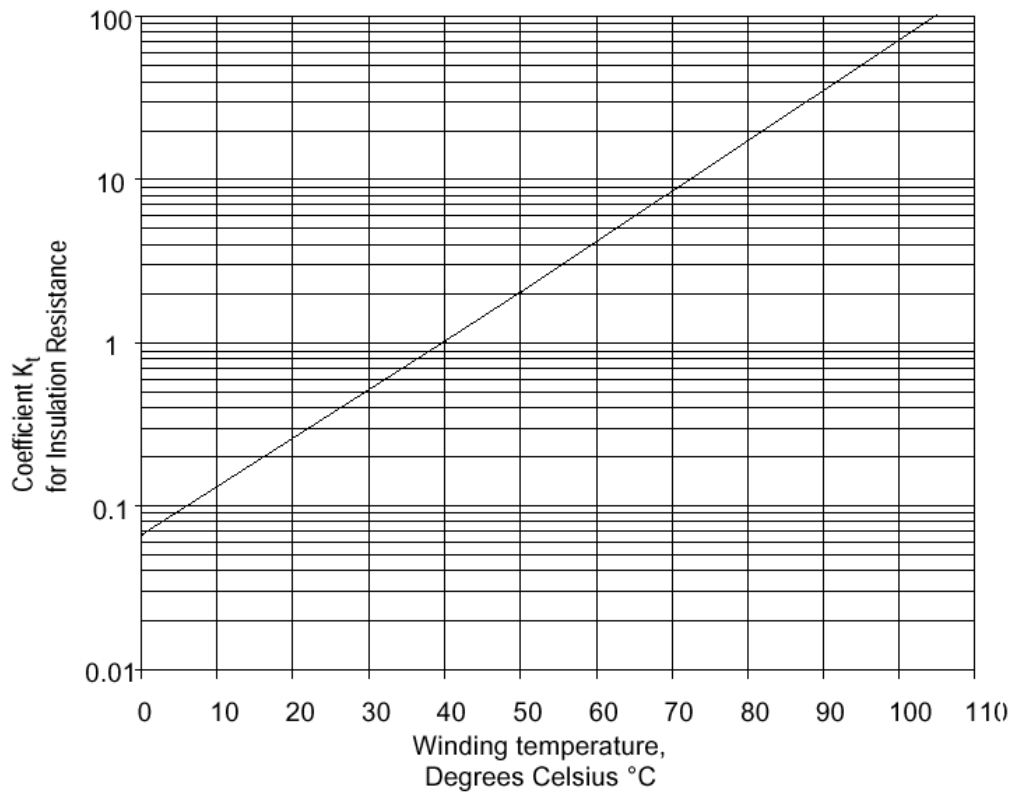

Figure 7-6 Correlation between the insulation resistance and the temperature

R = Insulation resistance value at a specific temperature

R40 = Equivalent insulation resistance at 40°C

$$R_{40} = k \times R$$

Example:

$R = 30 \text{ M}\Omega$ measured at 20°C

$k = 0.25$

$$R_{40} = 0.25 \times 30 \text{ M}\Omega = 7.5 \text{ M}\Omega$$

Table 7-4. Temperature values in degrees Celsius (°C) and degrees Fahrenheit (°F)

°C	0	10	20	30	40	50	60	70	80	90	100	110
°F	32	50	68	86	104	122	140	158	176	194	212	230

7.6.4.2 General considerations

The following consideration should be noted, before deciding any actions based upon the insulation resistance tests:

- If the measured value is considered too low the winding must be cleaned and/or dried. If these measures are not sufficient, expert help should be acquired
- Machines, that are suspected to have moisture problem, should be dried carefully independent of the measured insulation resistance value
- The insulation resistance value will decrease when the winding temperature rises
- The resistance is halved for every 10 ... 15 K temperature rise.

NOTE: The insulation resistance indicated in the test report is normally considerably higher than the values measured on site.

7.6.4.3 Minimum values for insulation resistance

Criteria for windings in a normal condition:

Generally, the insulation resistance values for dry windings should exceed the minimum values significantly. Definite values are impossible to give, because resistance varies depending on the machine type and local conditions. In addition, the insulation resistance is affected by the age and usage of the machine. Therefore, the following values can only be considered as guidelines.

The insulation resistance limits, which are given below, are valid at 40 °C, and when the test voltage has been applied for 1 minute or longer.

- Rotor

For induction machines with wound rotors: $R_{(1-10 \text{ min at } 40 \text{ }^\circ\text{C})} > 5 \text{ M}\Omega$

NOTE: Carbon dust on slip rings and naked copper surfaces lower the insulation resistance values of the rotor.

- Stator

For new stators: $R_{(1-10 \text{ min at } 40 \text{ }^\circ\text{C})} > 1000 \text{ M}\Omega$ If the measuring conditions are extremely warm and humid, $R_{(1-10 \text{ min at } 40 \text{ }^\circ\text{C})}$ values above 100 MΩ can be accepted

For used stators: $R_{(1-10 \text{ min at } 40 \text{ }^\circ\text{C})} > 100 \text{ M}\Omega$

NOTE: If the values given here are not reached, the reason for the low insulation resistance should be determined. A low insulation resistance value is often caused by excess humidity or dirt, although the actual insulation is intact.

7.6.4.4 Stator winding insulation resistance measurement

The insulation resistance is measured using an insulation resistance meter. The test voltage is 1000 VDC. The test time is 1 minute, after which the insulation resistance value is recorded. Before the insulation resistance test is conducted, the following actions must be taken:

- Check that the secondary connections of the current transformers (CT's), including spare cores are not open. See *Figure 7-7 Connections of the stator windings for insulation resistance measurements*
- Verify that all power supply cables are disconnected
- Verify that the frame of the machine and the stator windings not being tested are earthed
- The winding temperature is measured
- All resistance temperature detectors are earthed
- Possible earthing of voltage transformers (not common) must be removed.

The insulation resistance measuring should be carried out in the terminal box. The test is usually performed to the whole winding as a group, in which case the meter is connected between the frame of the machine and the winding; See *Figure 7-7 Connections of the stator windings for insulation resistance measurements*. The frame is earthed and the three phases of the stator winding remain connected at the neutral point, see *Figure 7-7 Connections of the stator windings for insulation resistance measurements*.

If the measured insulation resistance of the whole winding is lower than specified, and the phase windings can easily be disconnected from each other, each phase can also be measured separately. This is not possible for all machines. In this measurement, the tester is connected between the frame of the machine and one of the windings. The frame and the two phases not measured are earthed; see *Figure 7-7 Connections of the stator windings for insulation resistance measurements*.

When phases are measured separately, all star-points of the winding system must be removed. If the star-point of the component cannot be removed, as in a typical tri-phase voltage transformer, the whole component must be removed.

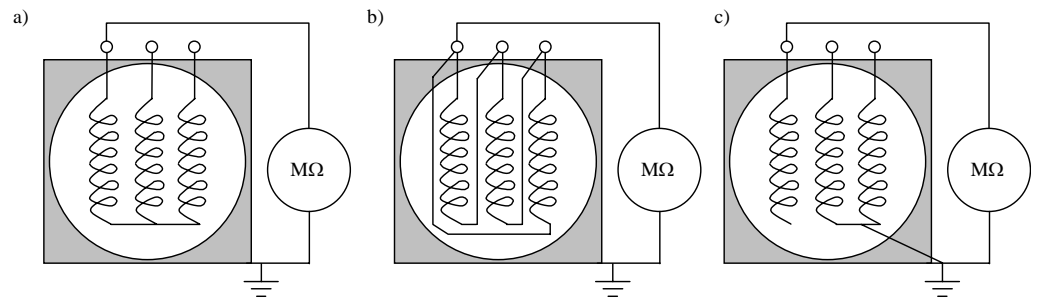

Figure 7-7 Connections of the stator windings for insulation resistance measurements

a) Insulation resistance measurement for star connected winding

b) Insulation resistance measurement for delta connected winding

c) Insulation resistance measurement for one phase of the winding. The 'MΩ' represents the insulation resistance meter.

After the insulation resistance measurement the winding phases must be earthed briefly in order to discharge them.

*****Following chapter for rotor type: Slip rings**

7.6.4.5 Rotor winding insulation resistance measurement

The insulation resistance of the rotor winding is measured with an insulation resistance meter. The test voltage of the rotor windings should be 1000 VDC. Required notes and measures:

- Verify that all power supply cables are disconnected from the main supply
- Verify the slip ring unit connection cables are disconnected from their supply
- Verify that the frame of the machine and the stator windings are earthed
- The shaft is earthed
- The rotor winding phases not been tested are earthed. The rotor winding can be internally connected in a delta or star connection. If this is the case, it is not possible to measure the phases individually
- The carbon brush connections are checked to be in good order
- The measurement device is checked
- The stator winding temperatures are measured, and considered as a reference value for the rotor winding temperature.

The insulation resistance meter is connected between the whole rotor winding and the shaft of the machine, see *Figure 7-8 Insulation resistance measurement of the rotor winding*. After performed rotor winding measurements, the rotor winding phases must be briefly earthed in order to discharge the windings.

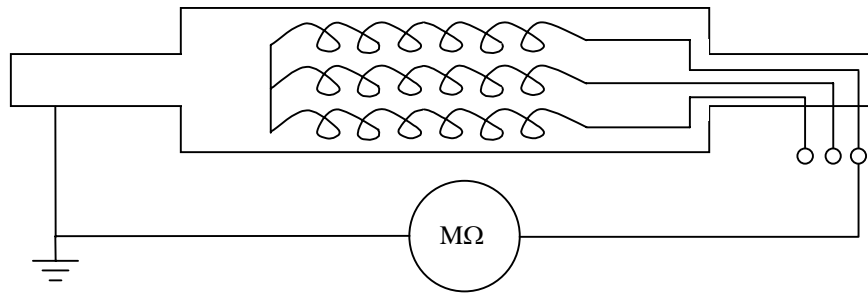

Figure 7-8 Insulation resistance measurement of the rotor winding

In the figure above the rotor is star-connected.

7.6.5 Insulation resistance measurement for auxiliaries

To ensure correct operation of the machines protections and other auxiliaries, their condition can be determined by an insulation resistance test. The procedure is described in detail in *Chapter 7.6 Maintenance of stator and rotor windings*. The test voltage for the space heater should be 500 VDC and for other auxiliaries 100 VDC. The insulation resistance measurement for Pt-100 detectors is not recommended.

7.6.6 The polarization index

For the polarization index test the insulation resistance is measured after the voltage has been applied for 15 seconds and 1 minute (or 1 minute and 10 minutes). The polarization index test is less dependent on the temperature than the insulation resistance. When the winding temperature is below 50°C (122°F), it may be considered independent of temperature. High temperatures can cause unpredictable changes in the polarization index, therefore the test should not be used at temperatures above 50°C (122°F).

Dirt and humidity accumulating in the winding normally reduces the insulation resistance, and the polarization index, as well as their dependence on temperature. Thus, the line in *Figure 7-6 Correlation between the insulation resistance and the temperature* becomes less steep. Windings with open creepage distances are very sensitive to the effects of dirt and humidity.

There are several rules for determining the lowest acceptable value with which the machine can be safely started. For the polarization index (PI), the values usually range between 1 and 4. Values close to 1 indicate that the windings are humid and dirty.

The minimum PI value for class F stator windings is more than 2.

NOTE: If the insulation resistance of the winding is in the range of several thousands of MΩ, the polarization index is not a meaningful criterion of the condition of the insulation, and it can be disregarded.

$$PI = \frac{R_{1\min}}{R_{15s}} \text{ or } \left(\frac{R_{10\min}}{R_{1\min}} \right)$$

7.6.7 Other maintenance operations

Usually, ABB-made winding are trouble free and in addition to periodical monitoring they require only occasional cleaning and drying as described above. If extraordinary circumstances occur and other maintenance is required, it is best to acquire professional help. The ABB After Sales organization is eager to assist in questions regarding maintenance of electrical machine winding, for contact information see *Chapter 9.1.5 After Sales contact information*.

*****Following chapters for rotor type: Slip rings**

7.7 Maintenance of slip rings and brush gear

A machine with slip rings will function properly only if the slip rings and the brush gear are inspected and subjected to maintenance regularly.

7.7.1 Care of slip rings

The sliding surfaces of the slip rings should be kept smooth and clean. The slip rings should be inspected and the surfaces of the insulation cleaned. Wearing of brushes produces coal dust that easily builds up conducting bridges over the insulation surfaces. Electric discharges may take place between slip rings and a flash might appear, leading to interruption in operation of the machine. The contact surface of slip rings forms a patina, or skin, together with the brushes. The patina can be seen as a colored surface, it is normal behavior and in many cases a benefit to brush operation, so the patina is not be considered as a fault in operation and should not be cleared away.

7.7.1.1 Standstill period

When a longer standstill period for the machine begins, the brushes should be lifted up. During transport, storage, installation or longer interruptions, the sliding surfaces of the slip-rings might be tarnished or covered with dirt, etc. Before restarting the machine, the sliding surfaces should be inspected and cleaned.

7.7.1.2 Wear

In case that the slip rings have become coarse or uneven, they should be ground or turned on a lathe. The asymmetry of the whole ring diameter should be less than 1.0 mm, but for a short distance, a value of maximum 0.2 mm is allowed. In case of the slip rings are worn out or badly burned, new rings should be assembled.

Measure the eccentricity of the slip-rings using a dial indicator gage. Let the measuring point lie on the slip ring or on the outer surface of a brush. The highest and lowest values during one turn of the shaft are recorded. The difference of the maximum and minimum values should be no more than 1.0 mm and locally no more than 0.2 mm. The difference of the outer diameters of the two slip rings shall preferably not be more than 2 mm.

7.7.2 Care of brush gear

The brush gear should be inspected and the surfaces of the insulation cleaned.

Wearing of brushes produces coal dust that easily builds up conducting bridges over the insulation surfaces. The coal dust is best removed by vacuum cleaning brush gear.

7.7.2.1 Brush pressure

The brush pressure should be evenly distributed over the whole contact surface, i.e. the brush should conform to the slip ring curvature. Brush pressure is one of the most important single factors in brush operation. The pressure should be 18-20 mN/mm² (180-200 g/cm²). Use a spring-balance to measure the brush pressure. Attach a spring balance to the tip of the lever pressing the brush and pull in a radial direction until the pressure is just relieved from the brush. Use a piece of paper between brush and press lever to detect when pressure is relieved, see *Figure 7-9 Checking brush pressure with spring balance.*

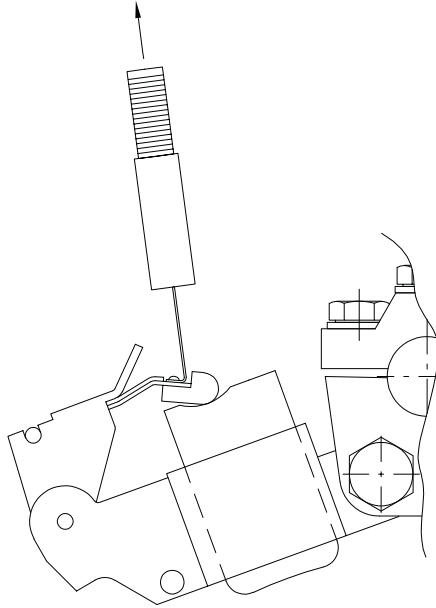

Figure 7-9 Checking brush pressure with spring balance

*****Following chapters for cooling type: Open air, Air-to-water and Air-to-air**

7.8 Maintenance of cooling units

The cooling units normally require little maintenance but it is advisable to regularly check their condition in order to ensure trouble-free operation.

*****Following chapter for cooling type: Open air**

7.8.1 Maintenance instructions for machines with open air cooling

The cooling air is normally circulated by a fan and/or by the rotor. The fan may be mounted on the shaft or driven by a separate motor. A connection to external air pressure is also possible. Depending on the machine design, the circulation may be axially symmetrical or asymmetrical. The cooling air should be as clean as possible, because any dirt, which drifts into the machine, causes contamination and reduces the efficiency of the cooling.

The upper covers of the standard weather protected machines are delivered with or without filters according to the specification. By special order, the upper cover is equipped with a differential pressure switch for monitoring the condition of the filters.

If the winding or cooling air temperature detectors show an abnormal temperature, a check of the cooling system has to be made. The two maintenance issues are to check the condition of air filters and to ensure good air circulation inside the machine. The machine interior should be cleaned and checked during overhauls or if problems arise.

Other possible causes for poor cooling system performance might include elevated ambient temperature or high intake air temperature. In addition, lubrication or bearing malfunction might lead to high bearing temperature.

A seemingly high temperature might also be caused by a problem in the temperature measurement system *Chapter 8.3.2 Pt-100 resistance temperature detectors*.

7.8.1.1 Cleaning of filters

The filters should be cleaned regularly. The cleaning interval depends on the cleanliness of the air in the surrounding environment. The filters have to be cleaned when the temperature detectors in the winding show abnormal temperature or approach the alarm level.

If a filter differential pressure monitoring system is being used, the filters should be changed immediately after a pressure alarm. The alarm level is such that 50% of the air filter surface is obstructed. The operating personnel should also manually inspect the filters frequently.

Remove the air filters for cleaning. If the surrounding air is sufficiently clean, the filters can be changed during operation. They should regularly be cleaned by vacuuming first from the upstream side, then on the discharge side. Periodically, a thorough wash with clean water is recommended to release any dirt not removed by vacuuming. When heavy grease concentrations are encountered, the filters should be washed with a detergent solution. This solution should be rinsed thoroughly before returning the filter to service. Be careful to install the air filters in the correct direction, i.e. the arrows on the air filter frame indicate the direction of airflow. Some filters can be installed in either direction. Refer also to the air filter manufacturer information.

*****Following chapters for cooling type: Air-to-water**

7.8.2 Maintenance instructions for air-to-water heat exchangers

If the temperature detectors show normal operating temperature, and the leakage detectors indicate no leaks, usually no additional supervision is required for the cooling system.

*****Following chapters for cooling type: Air-to-air**

7.8.3 Maintenance instructions for air-to-air heat exchangers

The cooling unit is installed on the machine. The air tubes in the heat exchanger are normally made of Aluminium.

7.8.3.1 Air circulation

The inner air is normally circulated by a fan and/or by the rotor. The fan may be mounted on the shaft or driven by a separate motor. Depending on the machine design, the circulation may be axially symmetrical or asymmetrical.

The outer air flow is normally created by a fan, mounted on the shaft or driven by a separate motor. Connection to external air pressure is also possible.

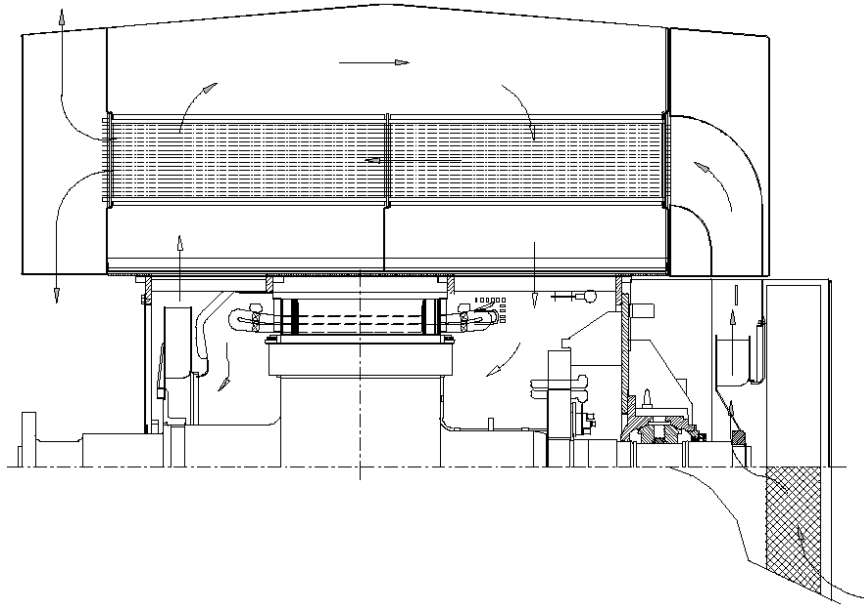

Figure 7-10 Cooling air flow (typical asymmetric construction)

The machine can be equipped with temperature detector(s) for monitoring the internal cooling air. If the temperature detectors show normal temperature, no additional maintenance to the supervision inspection is usually required for the cooling system.

If the temperature detectors show abnormal temperature or close to the alarm level in winding or in cooling air, the cooling system has to be checked. If the coolers have to be cleaned, see the instructions below.

7.8.3.2 Cleaning

Some fouling of the cooling surface and the tube wall will eventually occur. This fouling reduces the cooling capacity. The heat exchanger should therefore be cleaned at regular intervals, to be determined from case to case, depending of the properties of the cooling air. During the initial period of operation, the heat exchanger should be inspected frequently.

Blow the heat exchanger clean with compressed air or clean it with a suitable brush. Do not use a steel brush in aluminium tubes as it can damage the tubes; a soft round brass wire brush can be used instead.

7.8.4 Maintenance of external blower motors

The external blower motors are maintenance free units, e.g. the bearings of external blower motors are greased for life. A spare external blower motor is recommended. The maintenance of the blower motor is performed according to the motor's manual.

7.9 Repairs, disassembly and assembly

All the actions related to repairs, disassembly and assembly should be done by trained service personnel. For more information, please contact After Sales, see *Chapter 9.1.5 After Sales contact information*.

*****Following note for protection type: All machines for hazardous areas**

NOTE: Machines in hazardous areas must only be serviced by repair shops qualified and authorized by ABB.

*****Following note for rotor type: Permanent magnet**

NOTE: The permanent magnet synchronous machine must only be serviced by repair shops qualified and authorized by ABB. For more information on permanent magnet motors, please contact ABB.

Chapter 8 Trouble Shooting

8.1 Trouble shooting

This chapter is intended as a help in the event of an operational failure with an ABB delivered rotating electrical machine. The trouble shooting charts given below can aid in locating and repairing mechanical, electrical and thermal problems, and problems associated with the lubrication system. The checks and corrective actions mentioned should always be conducted by qualified personnel. If in any doubt, the After Sales of ABB should be contacted for more information or technical assistance regarding trouble shooting and maintenance.

8.1.1 Mechanical performance

Trouble shooting

Mechanical performance

Experienced malfunction		Possible cause	Corrective action
Vibration	Noise		
•	•	Lubrication malfunction	Check lubricant quality and quantity and lubrication system function
•	•	Bearing malfunction	Damaged bearing parts
•	•		Faulty bearing assembly
•	•	Faulty cooling fan(s)	Imbalanced or damaged fan(s)
	•	Malfunctioning cooling system	Inspect and repair cooling system
•	•	Machine misalignment	Check machine alignment
•	•	Rotor or shaft imbalance	Rebalance rotor
•	•	Vibration coming from connected machinery	Check the balance of connected machinery and coupling type
•	•	Axial load coming from connected machinery	Check alignment and coupling function and type
•	•	Faulty or incorrectly assembled coupling	Check coupling function
•		Insufficient foundation strength	Reinforce foundation as per ABB instructions
	•	Winding fault	Check windings
•	•	Excessive network unbalance	Check that network balance fulfils requirements
	•	Foreign material, moisture or dirt inside the machine	Check and clean machine interior, dry windings

8.1.2 Lubrication system and bearings

*****Following chapter for bearing type: Rolling bearing**

8.1.2.1 Lubrication system and rolling bearings

Trouble shooting

Lubrication system and antifriction bearings

oil supply and self lubrication

Experienced malfunction					
High bearing temperature	Lubricant leaks	Bearing noise or vibration	Possible cause		Corrective action
●		●	Insufficient lubrication	Insufficient amount of grease	Check bearing condition, add grease
●	●	●	Unsuitable grease quality or viscosity		Check ABB grease recommendations, change grease
●			Excessive axial forces	Faulty coupling or mounting	Check coupling, mounting and alignment
●		●	Reduced grease quality	Incorrect regreasing period	Check ABB recommendations, regrease
●		●		Faulty operating conditions	Check ABB operating and grease recommendations
●	●		Excessive lubrication		Clean bearing and add correct amount of lubricant
●		●	Damaged bearing parts	Impurities in grease	Change grease, check bearing condition
●		●		Bearing currents	Check bearing and insulation condition
●		●		Complete bearing failure	Replace bearing
●		●		Normal wearing	Replace worn bearing parts
●			Faulty instrumentation	Faulty temperature detector	Check bearing temperature measurement system
	●	●	Faulty bearing seals		Check bearing seals and lubricant quality
●			Incorrectly assembled bearing		Replace bearing, ensure correct assembly
●		●	Outer ring is rotating due to unbalanced load		Rebalance machine, repair bearing bore and replace bearing
		●	Bearing noise due to deformed roller element		Replace bearing
		●	Foreign matter inside the bearing		Clean bearing assembly, check seal conditions and replace bearing

***Following chapter for bearing type: Sleeve bearing

8.1.2.2 Lubrication system and sleeve bearings

***Following chart for bearing type: Sleeve bearing with self lubrication

Trouble shooting

Lubrication system and sleeve bearings self lubrication

Experienced malfunction					Possible cause	Corrective action	
High bearing temperature	Oil leaks	Oil inside the machine	Bearing noise or vibration	Visibly poor oil quality			
●			●	●	Insufficient lubrication	Low oil level	Check bearing for leakage, add oil
●	●	●		●	Unsuitable oil quality		Check ABB oil recommendations
●			●		Oil quality is reduced	Incorrect oil change period	Clean bearing and change oil
●	●		●	●	Excessive axial load	Faulty coupling or mounting	Check coupling, mounting and alignment
●	●		●		Machine misalignment		Realign machine
●			●		Incorrectly assembled bearing		Verify correct bearing assemblage and adjustments
●	●	●			Excessive amount of oil		Clean bearing and add correct amount of lubricant
●			●	●	Damaged bearing shells	Oil impurities	Change oil, check bearing condition, replace bearing shells
●			●			Bearing currents	Restore bearing insulation, replace bearing shells
●			●			Complete bearing failure	Replace bearing parts
●			●			Normal wearing	Replace bearing shells
●			●			Operating speed too low	Check the operating speed range of bearing
●					Faulty instrumentation	Faulty temperature detector	Check bearing temperature measurement system
	●				Damaged or worn-out bearing seals		Replace bearing seals
	●				External vacuum	Rotating equipment nearby	Check pressure levels, relocate rotating equipment
	●	●			Internal over pressure	Pressure compensation failure	Remove cause for internal over pressure
		●			Damaged machine seal		Replace or repair machine seal
●					Poor oil ring or disc operation		Open bearing and adjust operation
			●	●	Foreign matter inside the bearing		Clean bearing and check seal condition

***Following chart for bearing type: Sleeve bearing with flood lubrication

Trouble shooting

Lubrication system and sleeve bearings flood lubrication

Experienced malfunction					Possible cause	Corrective action	
High bearing temperature	Oil leaks	Oil inside the machine	Bearing noise or vibration	Visibly poor oil quality			
●			●	●	Insufficient lubrication	Oil flow malfunction	Check oil pump, oil reduction valve and oil filter
●						Oil viscosity too high	Check oil temperature and oil type
●	●	●		●	Unsuitable oil quality		Check ABB oil recommendations
●					Oil inlet temperature too high		Check lubrication system and adjust oil temperature
●			●		Oil quality is reduced	Incorrect oil change period	Clean bearing and change oil
●	●		●	●	Excessive axial load	Faulty coupling or mounting	Check coupling, mounting and alignment
●	●		●		Machine misalignment		Realign machine
●			●		Incorrectly assembled bearing		Verify correct bearing assemblage and adjustments
●			●	●	Damaged bearing shells	Oil impurities	Change oil, check bearing condition, replace bearing shells
●			●			Bearing currents	Restore bearing insulation, replace bearing shells
●			●			Complete bearing failure	Replace bearing parts
●			●			Normal wearing	Replace bearing shells
●			●			Operating speed too low	Check the operating speed range of bearing
●					Faulty instrumentation	Faulty temperature detector	Check bearing temperature measurement system
	●				Damaged or worn-out bearing seals		Replace bearing seals
	●				Oil flow too high	Faulty regulator settings	Check and correct oil flow
	●				Problem in oil return flow	Faulty oil piping	Check oil return pipe inclination
	●				External vacuum	Rotating equipment nearby	Check pressure levels, relocate rotating equipment
	●	●			Internal over pressure	Pressure compensation failure	Remove cause for internal over pressure
		●			Damaged machine seal		Replace or repair machine seal
	●				Faulty assembled or maintained lubrication piping		Check pipeline connections and oil filter tightness
			●	●	Foreign matter inside the bearing		Clean bearing and check seal condition

NOTE: For oil leakage of sleeve bearings, see *Chapter 8.2 Oil leakage of sleeve bearings*.

8.1.3 Thermal performance

***Following chapter for cooling type: Open air or ducted air

8.1.3.1 Thermal performance, open air cooling system

Trouble shooting

Thermal performance

open air cooling system

Experienced malfunction		Possible cause		Corrective action
High winding temperature	High cooling air temperature			
●	●	High intake air temperature	Ambient temperature too high	Add ventilation to decrease ambient temperature
●	●		Exiting air is pulled back in	Ensure sufficient clear distances surrounding the machine
●	●		Heat source nearby	Place heat sources further away, check ventilation
●	●	Faulty air flow	Dirty machine interior	Clean machine parts and air gaps
●	●		Faulty cooling arrangement	Inspect cooling arrangement condition and correct assembly
●	●		Air intakes are blocked	Clear air intakes of debris
●	●		Air filter is clogged	Clean or replace air filters
●	●	Damaged cooling fan(s)		Replace fan(s)
●	●	Cooling fan rotating in the wrong direction		Replace fan(s) or change rotating direction of external fan
●		Overload	Control system setting	Check machine controls, eliminate overload
●	●	Overspeed		Check actual speed and ABB speed recommendations
●		Network unbalance		Check that network balance fulfils requirements
●	●	Faulty instrumentation or measurement system		Check measurements, sensors and wiring
●		Winding fault		Check windings

NOTE: For high bearing temperatures, see *Table 8.1.2 Lubrication system and bearings*.

***Following chapter for cooling type: Air-to-air

8.1.3.2 Thermal performance, air-to-air cooling system

Trouble shooting

Thermal performance air-to-air cooling system

Experienced malfunction				
High winding temperature	High cooling air temperature	Possible cause		Corrective action
●	●	Low primary cooling circuit performance	Damaged cooling fan(s)	Replace fan(s)
●	●		Fan rotating in wrong direction	Replace fan(s)
●	●		Dirty machine interior	Clean machine parts and air gaps
●	●	Low secondary cooling circuit performance	Damaged external fan	Replace fan
●	●		Fan rotating in wrong direction	Change shaft mounted fan or correct external blower motor operation
●	●		Leaking cooler	Repair cooler
●	●	High intake air temperature	Ambient temperature too high	Add ventilation to decrease ambient temperature
●	●		Exiting air is pulled back in	Ensure sufficient clear distances surrounding the cooler
●	●		Heat source nearby	Place heat sources further away, check ventilation
●		Overload	Control system setting	Check machine controls, eliminate overload
●	●	Overspeed		Check actual speed and ABB speed recommendations
●		Network unbalance		Check that network balance fulfils requirements
●	●	Faulty instrumentation or measurement system		Check measurements, sensors and wiring
●		Too many starts		Let the machine cool down before restarting
●		Winding fault		Check windings

NOTE: For high bearing temperatures, see *Table 8.1.2 Lubrication system and bearings*.

***Following chapter for cooling type: Air-to-water

8.1.3.3 Thermal performance, air-to-water cooling system

Trouble shooting

Thermal performance

air-to-water cooling system

Experienced malfunction			Possible cause	Corrective action	
High winding temperature	High cooling air temperature	Water leakage alarm			
●	●		Low primary cooling circuit performance	Damaged cooling fan	Replace fan
●	●			Fan rotating in wrong direction	Change shaft mounted fan or correct external blower motor operation
●	●			Dirty machine interior	Clean machine parts and air gaps
●	●		Low secondary cooling circuit performance	Coolant pipes are blocked	Open cooler and clean pipes
●	●			Faulty coolant pump	Check and repair the pump
●	●			Faulty flow regulator settings	Check and adjust coolant flow
●	●	●		Leaking cooler header	Replace the cooler header
●	●			Air inside the cooler	Bleed the cooler through bleeder screw
●	●			Emergency cooling hatch open	Close emergency cooling hatch tightly
●	●		Cooling water inlet temperature too high	Adjust cooling water temperature	
●			Overload	Control system setting	Check machine controls, eliminate overload
●			Network unbalance		Check that network balance fulfils requirements
●	●	●	Faulty instrumentation or measurement system		Check measurements, sensors and wiring
●			Too many starts		Let the machine cool down before restarting
●			Winding fault		Check windings

NOTE: For high bearing temperatures, see *Table 8.1.2 Lubrication system and bearings*.

***Following chapter for cooling type: Rib cooled

8.1.3.4 Thermal performance, rib cooled

Trouble shooting

Thermal performance rib cooled

Experienced malfunction	Possible cause		Corrective action
	High winding temperature		
•	Overload	Control system setting	Check machine controls, eliminate overload
•	Overspeed		Check actual speed and ABB speed recommendations
•	Network unbalance		Check that network balance fulfils requirements
•	Faulty instrumentation or measurement system		Check measurements, sensors and wiring
•	Too many starts		Let the machine cool down before restarting
•	Winding fault		Check windings
•	Dirty machine exterior		Clean machine exterior
•	Air flow is reduced		Remove obstacles. Ensure sufficient air flow, <i>see Dimension Drawing of the machine</i>

NOTE: For high bearing temperature, see *Chapter 8.1.2 Lubrication system and bearings*.

*****Following chapters for bearing type: Sleeve bearing**

8.2 Oil leakage of sleeve bearings

The construction of a sleeve bearing is such that it is very difficult to avoid oil leakage completely, and therefore small amounts of leakage should be tolerated.

However, oil leakage can also appear because of reasons other than the bearing design, such as incorrect oil viscosity, overpressure inside the bearing, underpressure outside the bearing, or high vibration levels at the bearing.

If excessive oil leakage is noted, please check/verify the following:

- Verify that the oil used is according to specifications
- Re-tighten the bearing housing halves, and the labyrinth seal cover. This is especially important, if the machine has been stopped for a long time
- Measure the vibrations of the leaking bearing in three directions under full load. If the vibration level is high, the bearing housing might "loosen" just enough to permit the oil to wash away the sealant between the housing halves
- Open the bearing, clean the surfaces and apply new sealant between the bearing housing halves
- Verify that there is nothing, which might cause low pressure next to the bearing. A shaft or coupling cover can for instance be designed so that it will cause low pressure near the bearing
- Verify that there is no overpressure inside the bearing. Overpressure may be entering the bearing through the oil outlet piping from the oil lubrication unit. Apply breathers or vents to the bearing housing as to relieve the overpressure from the bearing
- In case of a flood bearing lubrication system, check that the slope of the oil outlet pipes is sufficient.

If excessive oil leakage is found even after all of the above and below mentioned things have been checked and verified, please fill in the form Oil Leakage's at RENK Sleeve Bearings and send it to the after sales and market support department.

8.2.1 Oil

In order for the bearings to function as expected, the oil has to meet certain criteria like viscosity and cleanliness, see *Chapter 7.5.2.2 Control of the lubricant* and *Chapter 7.5.2.3 Recommended control values for the lubricating oil*.

Viscosity

The bearings are designed to run with an oil of a certain viscosity, which is mentioned in the documentation provided with the electrical machine.

Incorrect viscosity will lead to lubrication failures, and can damage the bearings, as well as the shaft.

8.2.2 Sleeve bearings

The sleeve bearings used in rotating electrical machines are often 'standard bearings' used in a number of applications. Therefore, the bearing design in itself is normally not the cause of bearing leakages, and the reason for the leakage should be found elsewhere.

However, the bearing is assembled from several parts, and the joints between the parts can leak due to faulty assembly or lack of sealing compound.

Bearing housing

The bearing housing consists of an upper and lower half, which are joined together. In addition, labyrinth seals are mounted at the bearing housing entrance of the shaft. This construction is not completely hermetic, and therefore very small leakages have to be tolerated.

A tolerable amount of leakage for self-lubricating bearings is such that the bearing does not need a top-up between the oil change intervals.

The oil can leak from the bearing in two ways:

- Past the labyrinth seals
- Through the split line of the bearing housing.

Sealant

In order to prevent the oil from leaking from the bearing through any split lines, sealant is applied on the split lines. ABB recommends the Hylomar Blue Heavy sealing compound. Curil T or other similar compounds can be used as well.

8.2.3 Bearing verification

In case the oil leakage is suspected to originate from the bearing housing itself, the following steps can be taken:

1. Re-tighten the bearing housing

This is especially important during the commissioning of the machine, or if the machine has been standing still for a longer period, as the parts may set.

If the bearing housing halves are not in a tight fit in respect to each other, the oil might wash away the sealant from the split line. This in turn will cause oil leakage.

2. Open the bearing housing

The bearing housing can be opened, and new sealant applied on the split lines. Care has to be taken that no dirt or foreign matter enter the bearing during this procedure. The split lines have to be completely degreased before a thin layer of sealant is applied.

*****Following chapter for bearing type: Sleeve bearing with flood lubrication**

8.2.4 Oil container and piping

A separate oil container and piping is used only for flood-lubricated bearings.

Oil container

The oil container can be either a separate container, or in some cases, the crankcase of a diesel engine. In both cases, the container has to be well below the bearings, in order for the oil to flow to the container from the bearing.

The oil container should be constructed in such a way that no pressure can enter the oil return piping from the container towards the bearing.

Oil piping

The function of the oil return piping is to allow the oil to return to the oil tank with as little of friction as possible. This is normally obtained by choosing a piping diameter of a large enough diameter, so that the flow of the oil in the return line does not exceed 0.15 m/s (6 inch/s) based on the pipe cross section.

Install the oil outlet pipes downwards from the bearings at a minimum angle of 15° which corresponds to a slope of 250 - 300 mm/m (3 – 3½ inch/ft).

The assembling of the piping must be performed in such-a-way that above mentioned slope is present at all points of the piping.

*****Following chapter for bearing type: Sleeve bearing with flood lubrication**

8.2.5 Oil container and piping verification

In case the oil leakage is suspected to originate from the construction of the oil container or the oil piping, the following steps can be taken:

Pressure in oil container

The atmospheric pressure inside the oil container must be verified. The pressure may not be larger than the pressure outside the bearing. If this is the case, a breather must be installed to the oil container.

Oil piping

It should be verified that the piping has a sufficient diameter, is not clogged, and that the slope is downward and sufficient throughout the oil return piping.

8.2.6 Use

Causes for bearing leakages, apart from being installation-related, some causes are 'use' related.

*****Following paragraphs for bearing type: Sleeve bearing with flood lubrication**

Oil pressure

The inlet oil pressure for each bearing is calculated according to the desired oil flow, and therefore the oil pressure should be adjusted accordingly during commissioning.

The specific oil pressure value for each machine must be verified from the documentation provided with the machine.

*****Following paragraph for bearing type: Sleeve bearing with self lubrication**

Oil level

The oil level of a self-lubricated sleeve bearing needs to be checked regularly, see *Chapter 7.5.1.1 Oil level*.

Oil temperature

The correct lubrication oil temperature is essential in keeping the bearing at the correct operating temperature, in ensuring sufficient lubrication effect, and correct viscosity of the lubrication oil, see *Chapter 7.5.2.1 Lubrication oil temperature*.

Vibrations

All machines are subjected to, and designed to withstand vibrations. Large vibrations might cause the various parts in the bearing to function different as intended.

Heavy vibrations can cause different phenomena in the oil film between the shaft and the white metal, but this will rather seldom lead to oil leakages, but to bearing failures.

Heavy vibrations can cause the bearing housing parts to set, or to 'loosen up' just enough to allow the oil to enter the split surface between the upper and the lower bearing housing halves. The vibrations will cause the bearing housing parts to move in respect of each other. This can cause a 'pumping' effect in such a way, that oil will be pumped in and out from the split surface. This will eventually remove the sealant, and cause the bearings to leak.

Air pressure inside bearing

The bearing housing is not a hermetic compartment, and therefore any overpressure inside the bearing housing will escape the bearing housing via the labyrinth seals. In escaping, the air will bring oil mist with it, thus causing the bearing to leak.

Overpressure inside the bearing is normally caused by other components than the bearing itself. The most common reason for overpressure inside the bearing is overpressure in the oil return piping.

Air pressure outside of bearing

Similar to overpressure inside the bearing, under pressure outside the bearing will 'suck' air out from inside the bearing, thus bringing oil with it, and causing the bearing to leak oil.

Under pressure inside the bearing is normally not caused by the bearing itself, but by parts outside the bearing.

Under pressure near the bearing housing is caused by rotational parts moving the air next to them in such a way that a local under pressure is formed next to the exit of the shaft of the bearing.

8.2.7 Use verification

Oil

The oil quality must be verified.

*****Following paragraphs for bearing type: Sleeve bearing with flood lubrication**

The inlet pressure of the oil must be verified and adjusted accordingly.

The normal value for the oil pressure is $125 \text{ kPa} \pm 25 \text{ kPa}$ ($1.25 \text{ bar} \pm 0.25 \text{ bar}$), but the specific oil pressure value for each machine must be verified from the documentation provided with the machine.

*****Following paragraphs for bearing type: Sleeve bearing with self lubrication**

The oil level in the bearing must be verified.

The temperature of the oil must be verified. A too high temperature will cause the viscosity of the oil to diminish, thus making it easier to escape from the bearing.

NOTE: Bearings with only one Pt-100 temperature detector normally detect the temperature of the bearing, not the oil. The temperature of the oil is approximately 10°C (20°F) lower than the bearing temperature.

*****Following paragraph for bearing type: Sleeve bearing with flood lubrication**

The normal oil inlet temperature is in the range of 65°C to 75°C (150°F - 170°F), but must be verified from the documentation provided with the machine.

Vibrations

Vibration readings of the bearing housings should be taken in three directions: axial, transversal (horizontal) and vertical, see *Chapter 7.4.3 Vibrations*.

Air pressure inside the bearing

The air pressures inside and outside the bearings should be verified.

Overpressure is, as stated above, normally caused by overpressures in the oil tank. The overpressure from the oil tank is then transmitted to the bearing via the oil return piping.

The best way to measure the pressure inside a bearing, is from the oil fill entrance or the inspection glass on top of the bearing.

In case overpressure inside the bearing is found, the following measures should be taken in the following order:

- Mount breather in the oil tank if possible. This is not suitable for diesel engine crankcases
- Make sure the oil return pipe enters the oil tank below the oil level. This is essential for diesel engine crankcases

- Make a U-shaped 'water lock' on the oil return piping
- Install a breather on top of the bearing housing.

Air pressure outside the bearing

The air pressure near the exit of the shaft from the bearing needs to be verified. This is especially important if the bearing is flange mounted to the machine, or if the shaft is mounted inside a cover or other construction which might form a 'centrifugal fan' together with the shaft.

Flange bearings have two canals between the bearing housing and the flange, which normally are enough to compensate for any under pressure near the exit of the shaft from the bearing housing. However, if for some reason a very large under pressure is present near this area, the two canals might not be enough, and some air is additionally sucked from inside the bearing. This is especially likely to happen to sleeve bearings with axial thrust pads, as the oil flow in these bearings is larger than in pure radial bearings.

If a large under pressure is noticed or suspected, the air pressure has to be measured near the exit of the shaft from the bearing housing.

In order to verify that the under pressure outside the bearing can cause the leakage, the pressure outside the bearing (p_0) inside the bearing (p_2), and the pressure in the area between the end shield and the machine seal (p_1) must be measured as well. When measuring (p_1), the tube has to be inserted as deep as possible, and the canals must be temporarily closed, see *Figure 8-1 Verification of air pressure inside and outside of a sleeve bearing*.

In order to analyze the situation, p_1 and p_2 have to be compared with p_0 , which has to be measured free from any disturbances or turbulence near the machine. The following situations can appear:

- $p_0 = p_1 = p_2$. If all pressure readings are the same, the leakage is not caused by pressure differences. However, bear in mind what has been stated about diesel engines earlier
- $p_2 > p_1 (= p_0)$. If the pressure inside the bearing is larger than the outside pressure, there is only a situation with overpressure inside the bearing
- $p_2 (= p_0) > p_1$. If the pressure outside the bearing is smaller the pressure elsewhere, there is under pressure near the bearing
- $p_2 > p_0 > p_1$. If all pressure readings are different, there might be a situation where both overpressure inside the bearing, and under pressure outside the bearing are present.

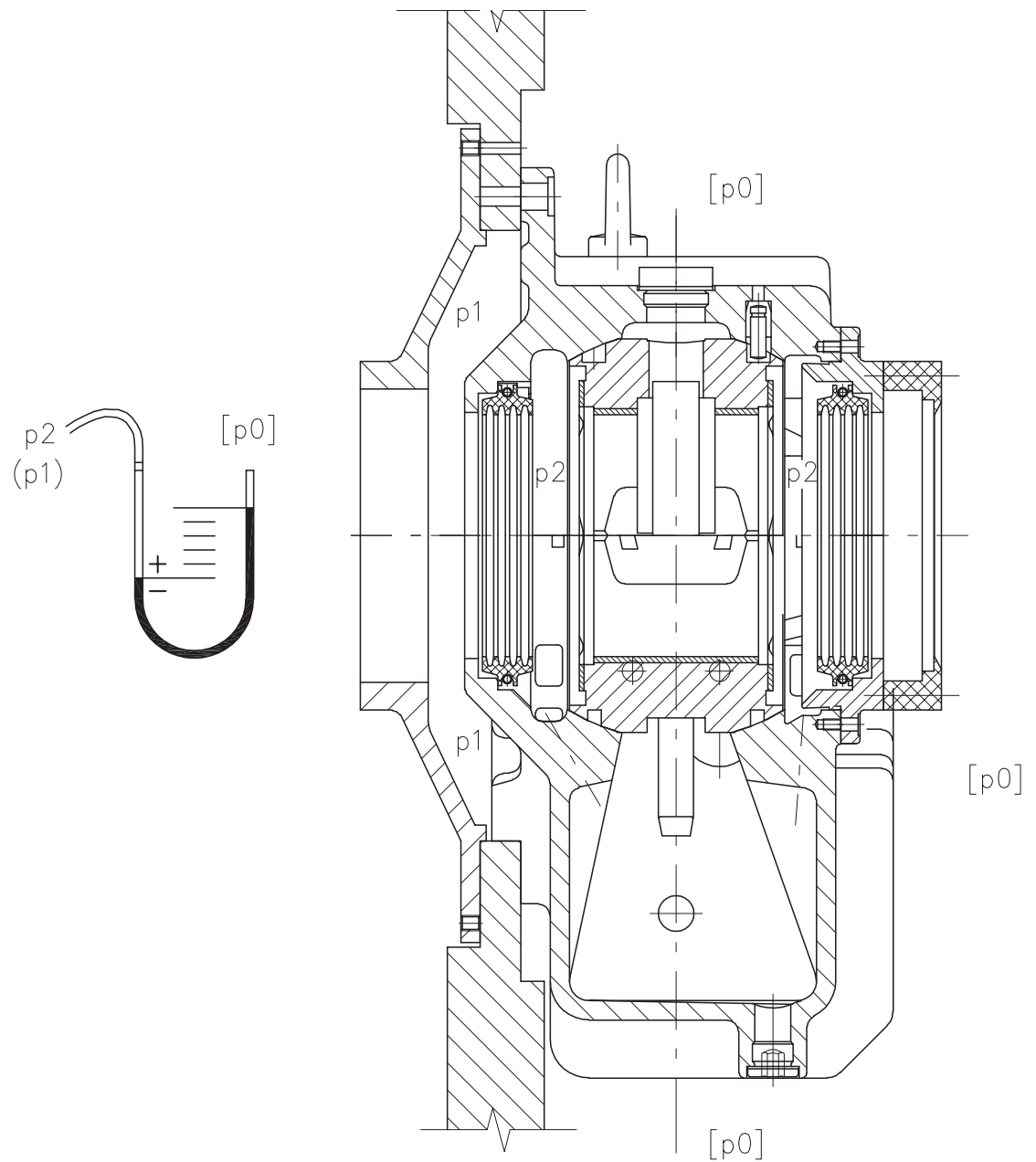

Figure 8-1 Verification of air pressure inside and outside of a sleeve bearing

If a large under pressure is found to be inside the machine, e.g. between the end shield and the machine seal, the situation is tricky; it is normally very difficult to remove the machine seal, and to re-seal it.

NOTE: In no case should a breather be installed to remedy under pressure in the bearing, as it will only make the leakage worse.

8.3 Electrical performance, excitation, control and protection

The electrical performance of a rotating electrical machine is mostly defined by the condition of the rotor and stator windings, and the operation of the excitation system, if applicable. The main machine winding maintenance is described in *Chapter 7.6 Maintenance of stator and rotor windings*. In this chapter, the focus is on the trouble shooting of the excitation, the control and protection systems.

8.3.1 Protection trips

The machine needs to be protected with alarms and trips for abnormal running conditions, both electrical and mechanical. Some of these protections can be reset and the machine restarted directly as the fault is located.

Examples of protections that, if they give an alarm or trip, may need further investigation:

- Diode fault protection
- High temperature in bearing, see *Chapter 7.5 Maintenance of bearings and lubrication system*
- High temperature in winding or in cooling air, see *Chapter 7.6 Maintenance of stator and rotor windings* and *Chapter 8.5 Thermal performance and cooling system*
- Overcurrent, current and voltage unbalance, bus bar voltage
- Vibration protection, *Chapter 7.4.2 Vibration and noise*.

8.3.2 Pt-100 resistance temperature detectors

Pt-100 resistance temperature detectors are an essential part in the machine's condition monitoring and protection system. They are used to measure temperatures in the windings, bearings and in the cooling air. The Pt-100 detector uses a fine platinum filament for the temperature measurement, which can be damaged e.g. by incorrect handling or excessive vibration.

The following symptoms might suggest a problem in a Pt-100 detector:

- Infinite or zero resistance over the detector
- Disappearance of measurement signal during, or after start up
- A significantly different resistance value in a single detector.

If a Pt-100 failure is suspected the findings should always be confirmed from the connection box, by measuring the resistance at the detector with its cables disconnected. The findings should be registered. For the correct measuring current see the appropriate Pt-100 detector. For resistance values at different temperatures, see *Table 8-1 Temperature values for Pt-100 elements*.

Table 8-1. Temperature values for Pt-100 elements

PT100 RES Ω	TEMP °C	TEMP °F	PT100 RES Ω	TEMP °C	TEMP °F	PT100 RES Ω	TEMP °C	TEMP °F
100.00	0	32.00	127.07	70	158.00	153.58	140	284.00
100.78	2	35.60	127.84	72	161.60	154.32	142	287.60
101.56	4	39.20	128.60	74	165.20	155.07	144	291.20
102.34	6	42.80	129.37	76	168.80	155.82	146	294.80
103.12	8	46.40	130.13	78	172.40	156.57	148	298.40
103.90	10	50.00	130.89	80	176.00	157.31	150	302.00
104.68	12	53.60	131.66	82	179.60	158.06	152	305.60
105.46	14	57.20	132.42	84	183.20	158.81	154	309.20
106.24	16	60.80	133.18	86	186.80	159.55	156	312.80
107.02	18	64.40	133.94	88	190.40	160.30	158	316.40
107.79	20	68.00	134.70	90	194.00	161.04	160	320.00
108.57	22	71.60	135.46	92	197.60	161.79	162	323.60
109.35	24	75.20	136.22	94	201.20	162.53	164	327.20
110.12	26	78.80	136.98	96	204.80	163.27	166	330.80
110.90	28	82.40	137.74	98	208.40	164.02	168	334.40
111.67	30	86.00	138.50	100	212.00	164.76	170	338.00
112.45	32	89.60	139.26	102	215.60	165.50	172	341.60
113.22	34	93.20	140.02	104	219.20	166.24	174	345.20
113.99	36	96.80	140.77	106	222.80	166.98	176	348.80
114.77	38	100.40	141.53	108	226.40	167.72	178	352.40
115.54	40	104.00	142.29	110	230.00	168.46	180	356.00
116.31	42	107.60	143.04	112	233.60	169.20	182	359.60
117.08	44	111.20	143.80	114	237.20	169.94	184	363.20
117.85	46	114.80	144.55	116	240.80	170.58	186	366.80
118.62	48	118.40	145.31	118	244.40	171.42	188	370.40
119.40	50	122.00	146.06	120	248.00	172.16	190	374.00
120.16	52	125.60	146.81	122	251.60	172.90	192	377.60
120.93	54	129.20	147.57	124	255.20	173.63	194	381.20
121.70	56	132.80	148.32	126	258.80	174.37	196	384.80
122.47	58	136.40	149.07	128	262.40	175.10	198	388.40
123.24	60	140.00	149.83	130	266.00	175.84	200	392.00
124.01	62	143.60	150.57	132	269.60	176.57	202	395.60
124.77	64	147.20	151.33	134	273.20	177.31	204	399.20
125.54	66	150.80	152.04	136	276.80	178.04	206	402.80
126.31	68	154.40	152.83	138	280.40	178.78	208	406.40

There are two possible remedies for stator Pt-100 detector damage. If there are operational spare detectors remaining in the stator core, they can be taken into use. If all the working factory assembled detectors are in use, a new detector can be retrofitted in the winding end.

*****Following chapter for rotor type: Slip rings**

8.4 Slip rings and brushes

8.4.1 Brush wear

In case the brushes are wearing rapidly or unevenly, the following points shall be observed:

- Is the brush pressure within the specified range? See *Chapter 7.7.2.1 Brush pressure*.
- Are all brush pigtail cables reliably connected?
- Are the sliding surfaces of the slip rings deteriorated?
- Is it probable that carbon brushes have absorbed oil or moisture?
- Is the brush quality as specified for the machine?

Always when feasible:

- Control that the brushes are in good condition and that they can move freely in the brush holders
- Check that the brush pigtail cables are in order and that they are reliably connected
- Remove coal dust by vacuum cleaning.

8.4.2 Brush sparking

Any possible sparking of the brushes can be observed through a window in the slip ring enclosure. Sparking is often an indication of inadequate operation. Measures to prevent sparking must be taken immediately. The reasons of sparking shall be cleared up and undisturbed running restored. Possible causes for sparking:

- Inadequate loading condition
- Brushes sticking in their holders
- Brushes too loose in their holders
- Loose connection of brush terminal
- Imperfect brush bedding
- Incorrect or unequal brush pressure
- The sliding surfaces of the slip-rings are deteriorated
- The type of carbon brushes is not acceptable for the operating conditions
- Misalignment of shaft couplings
- The machine is out of balance
- Worn bearings giving unequal air gaps.

8.5 Thermal performance and cooling system

There are two fundamental reasons that might cause an increase in the machine's temperature:

- The effect of the cooling system has declined
- The machine is producing excessive amount of heat.

If the machine temperature exceeds the normal values, measures should be taken to determine which one of the above mentioned two causes is dominant cause in a particular incident.

NOTE: An excessive heat production might be caused by a winding problem or by network unbalance, and in these cases corrective actions on the cooling system would be ineffective or harmful.

If the winding or cooling air temperature detectors show an abnormal temperature, a check of the cooling system has to be done. Two separate maintenance issues affect the cooling system. The apparent part is to ensure the uninterrupted and correct operation of the heat exchanger. This task is accomplished by periodically cleaning and checking the heat exchanger for correct operation.

The air or water flow through the heat exchanger must also be checked. If the cooler is equipped with an external blower fan, its operation needs also to be checked.

The less apparent but equally important part is to ensure good air circulation in the primary cooling circuit inside the machine. This task can be fulfilled by cleaning and checking the machine interior during overhauls or if problems arise.

Other possible causes for poor heat exchanger performance might include elevated ambient temperature, high intake air or water temperature, and low air or water flow.

In addition, lubrication or bearing malfunction might lead to high bearing temperature. A seemingly high temperature might also be caused by a problem in the temperature measurement system *Chapter 8.3.2 Pt-100 resistance temperature detectors*.

Chapter 9 After Sales Support and Spare Parts

9.1 After Sales

The After Sales support for rotating electrical machines manufactured by ABB, and Strömberg in Helsinki, Finland since 1889.

9.1.1 Site Services

The Site Services department provides:

- Installation and commissioning
- Maintenance and inspections
- Trouble shooting and service
- Upgrading and modifications.

9.1.2 Spare Parts

The Spare Parts department:

- Co-ordinates spare parts packages delivered with the machine
- Sells genuine spare parts after the machines has been delivered.

For spare part packages, see *Chapter 9.2 Spare parts for rotating electrical machines*.

9.1.3 Support and Warranties

The Support department:

- Handles warranty issues under warranty period based on written claims
- Makes warranty determination
- Decides about corrective actions
- Provides technical support.

9.1.4 Support for Service Centers

The Service Center Support provides help for authorized Service Centers in questions concerning the mechanical construction as well as in electromagnetic and insulation technology issues.

9.1.5 After Sales contact information

Contact the After Sales department by:

- Phone 7 am - 5 pm (GMT +2): +358 (0)10 22 11
- 24-Hour Support Line: +358 (0)10 22 27100

- Fax: +358 (0)10 22 22544
- e-mail for spare parts: aftersales.machines@fi.abb.com
- e-mail for site services: siteservice.machines@fi.abb.com
- e-mail for warranties and technical support: support.machines@fi.abb.com

NOTE: If available, please add the serial number of the machine (seven digits, starting with 45#####) to your e-mail for reference information.

9.2 Spare parts for rotating electrical machines

9.2.1 General spare part considerations

The machines manufactured by ABB are designed and manufactured to provide reliable and trouble-free operation for decades. This requires, however, that the machines are properly maintained and operated. This maintenance includes changing of parts subjected to normal wear.

There is always an inevitable amount of uncertainty related to wearing. The wear rates of these parts vary greatly according to application, environment and particular conditions. Therefore, the condition of these parts should be checked regularly and a sufficient amount of spare parts should be kept in stock. These spares help to minimize down time if the need appears. The extent of the stock should be decided based upon the importance of the application, the availability of the particular spare part and the expertise of the local maintenance personnel.

9.2.2 Periodical part replacements

There is always mechanical wear when two moving surfaces are in contact with each other. In electrical machines most of the mechanical wear occurs between the rotating shaft and stationary parts. The bearing parts such as rolling bearings, bearing shells and oil rings in sleeve bearings will eventually wear out and need to be replaced, even if correct lubrication is maintained. Other wearing parts include seals that are in constant contact with the rotating shaft and brushes, brush gears and slip rings of the slip ring unit.

The parts mentioned above make an extensive, but not a complete, list of the mechanically wearing parts. These parts have an estimated life span, but as mentioned earlier, their actual durability can vary significantly. For this reason, at least these parts should be kept in stock. It should also be noted that the replacement of these parts, due to normal wearing, is not covered by the warranty.

9.2.3 Need of spare parts

Other types of wear occur due to elevated temperatures, electrical disturbances and chemical reactions. The wear of the diodes in the rectifier bridge is usually related to abnormal electrical operating conditions. It is usually a slow process, but it is strongly dependent on the operation conditions of the machines and system disturbances.

Air filters, which protect the machine interior from contamination, become themselves saturated with air impurities and need to be replaced to ensure the correct operation of the cooling unit, and the continuous protection of sensitive machine parts.

The electrical windings of the ABB machines have good protection against wear, but only if correct maintenance and operating conditions are followed. The correct operating temperature must not be exceeded and the windings must be cleaned from dirt regularly. The winding can also be subjected to accelerated wear due to a number of electrical disturbances.

There are stator winding Pt-100 temperature detectors located inside the stator core slots, which cannot be replaced. Therefore, the ABB practice is to add spare Pt-100 detectors in the stator core. These detectors are not to be considered as regular spare parts because they are intended to be used as a replacement in case of a stator Pt-100 element failure during commissioning. However, these elements can be taken into use also during operation if the primary detector fails. If the spare element should fail, the possible corrective action is to add Pt-100 elements into the stator winding end.

9.2.4 Selection of the most suitable spare part package

ABB provides three levels of ready-made spare part packages. The personnel best informed of the machine's operational conditions should select the most suitable package based on criticality of the application and on the financial risk related to the duration of downtime and loss of production.

Operational spare part package for commissioning and to ensure usability:

- These are the most essential spare parts that should always be available.

Recommended spare part package for trouble shooting and scheduled maintenance:

- These parts should be available during medium term maintenance. These parts also enable fast recovery in case of failure in the accessories.

Capital spare parts to reduce repair time in case of serious damage:

- These spare parts are recommended when the machine is a part of an essential process. These spare parts enable fast recovery even in case of a serious damage.

9.2.5 Typical recommended spare parts in different sets

Below is presented a general recommendation of the typical spare parts for different packages. To receive a quotation for specific parts for a specific machine, please contact the ABB After Sales organization.

Please note that even though ABB has customized the spare part sets to match the machine, they might contain references to accessories not found on all machines.

*****The following chapters for product family: HXR**

9.2.5.1 Operational spare part package

Spare part	Amount
Bearing RTD	1 pc

Alternatively for rolling bearing machines:

Rolling bearing	2 pcs
-----------------	-------

Alternatively for sleeve bearing machines:

Spare part	Amount
Bearing shell for DE	1 pc
Bearing shell for NDE	1 pc
Bearing oil ring for DE	1 pc
Bearing oil ring for NDE	1 pc
Bearing labyrinth seals for DE	2 pcs
Bearing labyrinth seals for NDE	2 pcs

9.2.5.2 Recommended spare part package

Spare part	Amount
Operational spare part package	1 pc
Space heater	1 pc
Stator Pt-100, retrofit kit	1 pc
Support or bushing insulators	1 pc

9.2.5.3 Capital spare parts

Spare part	Amount
Stator	1 pc
Rotor	1 pc

*****The following chapters for product family: AMA, AMB and AMI**

9.2.5.4 Operational spare part package

Spare part	Amount
Air filters (for IPW24/IC01 machine)	1 set
Water leakage detector (for IP55/IC81W machine)	1 pc
Bearing RTD	1 pc

Alternatively for rolling bearing machines:

Rolling bearing	2 pcs
-----------------	-------

Spare part	Amount
------------	--------

Alternatively for sleeve bearing machines:

Bearing shell for DE	1 pc
Bearing shell for NDE	1 pc
Bearing oil ring for DE	1 pc
Bearing oil ring for NDE	1 pc
Bearing labyrinth seals for DE	2 pcs
Bearing labyrinth seals for NDE	2 pcs

9.2.5.5 Recommended spare part package

Spare part	Amount
Operational spare part package	1 pc
Space heater	1 pc
Stator Pt-100, retrofit kit	1 pc
Water cooler element	1 pc
Support or bushing insulators	1 pc

9.2.5.6 Capital spare parts

Spare part	Amount
Rotor	1 pc
Stator	1 pc

***The following chapters for product family: AMK

9.2.5.7 Operational spare part package

Spare part	Amount
Air filters (for IPW24/IC01 machine)	1 set
Air filter for slip ring carbon dust	1 pc
Brushes	1 set
Brush holder	1 set
Water leakage detector (for IP55/IC81W machine)	1 pc
Bearing RTD	1 pc

Alternatively for rolling bearing machines:

Rolling bearing	2 pcs
-----------------	-------

Alternatively for sleeve bearing machines:

Bearing shell for DE	1 pc
Bearing shell for NDE	1 pc
Bearing oil ring for DE	1 pc
Bearing oil ring for NDE	1 pc
Bearing labyrinth seals for DE	2 pcs
Bearing labyrinth seals for NDE	2 pcs

9.2.5.8 Recommended spare part package

Spare part	Amount
Operational spare part package	1 pc
Space heater	1 pc
Space heater for slip ring unit	1 pc
Slip ring unit	1 pc
Stator Pt-100, retrofit kit	1 pc
Pressure switch for condition monitoring of brush dust filter	1 pc
Water cooler element	1 pc
Support or bushing insulators	1 pc

9.2.5.9 Capital spare parts

Spare part	Amount
Rotor	1 pc
Stator	1 pc

9.2.6 Order information

To ensure fast and correct spare part order and delivery, our After Sales personnel should be provided with the serial number of the machine in question. The serial number can be found either on the rating plate fixed to the machine frame, or stamped on the machine frame. In addition, provide specific and detailed information about the parts ordered.

The contact information of ABB's After Sales organization can be found in *Chapter 9.1.5 After Sales contact information*.

Chapter 10 Recycling

10.1 Introduction

ABB is committed to its environmental policy. ABB continuously strives to make its products more environmentally sound by applying results obtained in recyclability and life cycle analyses. Products, manufacturing processes and even logistics have been designed to take environmental aspects into account. ABB's environmental management system, certified to ISO 14001, is the tool for carrying out the environmental policy.

The following instructions should only be seen as recommendations for environmentally sound disposal of machines. It is the customer's responsibility to ensure that local regulations are followed. Some customer-specific items may not be included in this User's Manual. Additional documentation will be found in the project documentation.

10.2 Average material content

The average material content used in the manufacturing of the electrical machine is as follows:

	Cast iron frame induction machines	Modular steel frame induction machines
Steel	46 - 55 %	77 - 83 %
Copper	7 - 12 %	10 - 12 %
Cast iron	35 - 45 %	1 - 5 %
Aluminium	0 - 2 %	0 - 1 %
Plastics, rubber, insulation materials etc.	1 - 2 %	1 - 2 %
Stainless steel	less than 1 %	less than 1 %
Other	less than 1 %	less than 1 %

10.3 Recycling of packaging material

Once the machine has arrived on site, the packaging material will need to be removed.

- Any wood packaging can be burned
- For some countries, the packaging used for shipping by sea is made of impregnated wood that must be recycled according to local regulations
- Plastic material around the machine can be recycled
- Any anti-corrosive agent covering the machine surface can be removed using a petrol based detergent and a cleaning rag. The rag must be disposed of in accordance with local regulations.

10.4 Dismantling of the machine

Dismantling the machine is a basic procedure as it is assembled with bolts. However, due to the weight, it requires an operator trained in handling heavy components to prevent dangerous situations.

10.5 Separation of different materials

10.5.1 Frame, bearing housing, covers and fan

These parts are made of structural steel, which can be recycled according to local instructions. All the auxiliary equipment, cabling as well as bearings have to be removed before melting the material.

10.5.2 Components with electrical insulation

The stator and the rotor are the main components, which include electrical insulation materials. There are, however, auxiliary components which are constructed of similar materials and which are hence dealt with in the same manner. This includes various insulators used in the terminal box, exciter, voltage and current transformers, power cables, instrumentation wires, surge arrestors and capacitors. Some of these components are used only in synchronous machines and some are used only in a very limited number of machines.

All these components are in an inert stage once the manufacturing of the machine has been completed. Some components, in particular the stator and the rotor, contain a considerable amount of copper which can be separated in a proper heat treatment process, where the organic binder materials of the electrical insulation are gasified. To ensure a proper burning of the fumes, the oven shall include a suitable after burning unit. The following conditions are recommended for the heat treatment and for the after burning to minimize the emissions from the process:

Heat treatment

Temperature: 380-420°C (716...788°F)

Duration: After obtaining 90% of the target temperature, the object shall stay a minimum of five hours at this temperature

After burning of the binder fumes

Temperature: 850-920°C (1562-1688°F)

Flow rate: The binder fumes shall stay a minimum of three seconds in the burning chamber

NOTE: The emission consists mainly of O₂-, CO-, CO₂-, NO_x-, C_xH_y-gases and microscopic particles. It is on the user's responsibility to ensure that the process complies with the local legislation.

NOTE: The heat treatment process and the maintenance of the heat treatment equipment require special care in order to avoid any risk for fire hazards or explosions. Due to various installations used for the purpose it is not possible for ABB to give detailed

instructions of the heat treatment process, or the maintenance of the heat treatment equipment and these aspects must be taken care of by the customer.

10.5.3 Permanent magnets

If the permanent magnet synchronous machine is melted down as a whole, nothing needs to be done to the permanent magnets.

If the machine is dismantled for more thorough recycling and if the rotor must be transported after it, it is recommended that the permanent magnets are demagnetized. The demagnetization is done by heating the rotor in the oven until the permanent magnets reach a temperature of +300 °C (572°F).

WARNING: Magnetic stray fields, caused by an open or disassembled permanent magnet synchronous machine or by a separate rotor of such a machine, may disturb or damage other electrical or electromagnetic equipment and components, such as cardiac pacemakers, credit cards and equivalent.

10.5.4 Hazardous waste

The oil from the lubrication system is a hazardous waste and has to be handled according to local instructions.

10.5.5 Land fill waste

All insulation material can be handled as a land fill waste.

COMMISSIONING REPORT

Rating plate information:	
	Serial no.
Manufacturer:	ABB Oy
Address:	P.O. Box 186 FIN-00381 HELSINKI FINLAND
Telephone:	+358 (0) 10 22 11
Fax:	+358 (0) 10 22 22544
Customer:	
Customer address:	
Contact person:	
Telephone:	
Mobile phone:	
Fax:	
Email:	

1 Transportation

General:

Arrival date of the machine:	
Inspection date and location:	
Signature of consignee:	
Open box inspection:	<input type="checkbox"/> no <input type="checkbox"/> yes, done by:

Damages:

Packing list:	<input type="checkbox"/> no <input type="checkbox"/> yes, missing items:
Machine:	<input type="checkbox"/> no <input type="checkbox"/> yes, what kind of:
Package:	<input type="checkbox"/> no <input type="checkbox"/> yes, what kind of:
Accessories:	<input type="checkbox"/> no <input type="checkbox"/> yes, what kind of:
Spare parts + tools:	<input type="checkbox"/> no <input type="checkbox"/> yes, what kind of:

Actions taken in response to damages:

Photographed:	<input type="checkbox"/> no <input type="checkbox"/> yes, date:
Reported to the transportation company:	<input type="checkbox"/> no <input type="checkbox"/> yes, to whom: date:
Reported to the supplier:	<input type="checkbox"/> no <input type="checkbox"/> yes, to whom: date:
Reported to the insurance company:	<input type="checkbox"/> no <input type="checkbox"/> yes, to whom: date:

Method of transportation:

Railway
 Airfreight
 Truck
 Mail
 Shipped by M/S _____
 Other:

Comments:

2 Storage

General:

Storage:	<input type="checkbox"/> no <input type="checkbox"/> yes, begin: _____ end: _____
Storage time longer than 6 months:	<input type="checkbox"/> no <input type="checkbox"/> yes
Person responsible for storage:	

Storage place:

	<input type="checkbox"/> indoors <input type="checkbox"/> outdoors
	<input type="checkbox"/> in packing case <input type="checkbox"/> protected by a waterproof cover
	Daily temperature: min/max. _____ - _____ °C Humidity: _____ %

Storage actions:

Transportation package is ventilated:	<input type="checkbox"/> no <input type="checkbox"/> yes
External heating/fan is used:	<input type="checkbox"/> no <input type="checkbox"/> yes, type: _____
Machine space heaters are used:	<input type="checkbox"/> no <input type="checkbox"/> yes, voltage: _____
Bearings are flushed:	<input type="checkbox"/> no <input type="checkbox"/> yes, oil type: _____
Bearing shells are removed:	<input type="checkbox"/> no <input type="checkbox"/> yes, date: _____
Shaft end anti-corrosion protection checked:	<input type="checkbox"/> no <input type="checkbox"/> yes, type: _____
Shaft end anti-corrosion protection renewed:	<input type="checkbox"/> no <input type="checkbox"/> yes, date: _____
The rotor is turned 10 revolutions every two months:	<input type="checkbox"/> no <input type="checkbox"/> yes
There are vibrations in the storage place:	<input type="checkbox"/> no <input type="checkbox"/> yes, _____ mm/s, rms
There are corrosive gases in the air:	<input type="checkbox"/> no <input type="checkbox"/> yes, what kind of: _____
Brushes are lifted up:	<input type="checkbox"/> no <input type="checkbox"/> yes
Machine documents are saved and protected for future use:	<input type="checkbox"/> no <input type="checkbox"/> yes, location: _____

Comments:

3 Mechanical Installation

Foundation is checked according to machine drawing:	<input type="checkbox"/> no <input type="checkbox"/> yes, drawing number: _____						
Possible foundation anchor bolts or sole plates are mounted according to instructions:	<input type="checkbox"/> no <input type="checkbox"/> yes						
Air gap is measured, if applicable: For pedestal bearings, mark values 1-4, and for flanged bearings, values A-D 1 _____ A _____ 2 _____ B _____ 3 _____ C _____ 4 _____ D _____	<table style="width: 100%; border: none;"> <tr> <td style="text-align: center; width: 33%;">D-end top</td> <td style="text-align: center; width: 33%;">N-end top</td> <td style="text-align: center; width: 33%;">Exciter N-end top</td> </tr> <tr> <td style="text-align: center;"></td> <td style="text-align: center;"></td> <td style="text-align: center;"></td> </tr> </table>	D-end top	N-end top	Exciter N-end top			
D-end top	N-end top	Exciter N-end top					
For alignment of the coupling, use either values 1-4 or values A-D 1 _____ 2 _____ 3 _____ 4 _____ A _____ B _____ C _____ D _____	<table style="width: 100%; border: none;"> <tr> <td style="text-align: center; width: 50%;">Radial alignment of coupling top</td> <td style="text-align: center; width: 50%;">Angular alignment of coupling top</td> </tr> <tr> <td style="text-align: center;"></td> <td style="text-align: center;"></td> </tr> </table> <p>Axial position of the rotor: ET #1: _____ mm, ET #2: _____ mm</p> <p>Axial distance between shaft ends: _____ mm</p> <p>Rotor support distance:</p> <div style="text-align: center;"> <p>_____ mm _____ mm</p> </div>	Radial alignment of coupling top	Angular alignment of coupling top				
Radial alignment of coupling top	Angular alignment of coupling top						
Crankshaft deflection is checked:	<input type="checkbox"/> no <input type="checkbox"/> yes						
Tapered guide pins are used to lock the position of the machine after alignment:	<input type="checkbox"/> no <input type="checkbox"/> yes						
Foundations bolts are tightened with torque wrench:	<input type="checkbox"/> no <input type="checkbox"/> yes, bolt size: _____ torque: _____ Nm						
Bolt lubrication:	<input type="checkbox"/> dry <input type="checkbox"/> oil, <input type="checkbox"/> MoS ₂						
Cooling water:	<input type="checkbox"/> no <input type="checkbox"/> yes, amount: <input type="checkbox"/> m ³ /s						
Cooling element piping:	<input type="checkbox"/> flexible <input type="checkbox"/> rigid						
Transport locking device is removed:	<input type="checkbox"/> no <input type="checkbox"/> yes						
Rotor rotates without noise or scraping:	<input type="checkbox"/> no <input type="checkbox"/> yes						

4 Lubrication check

4.1 Self lubrication

Bearing oil:	Manufacturer: _____ Type: _____
The oil quality is the same as recommended:	<input type="checkbox"/> no <input type="checkbox"/> yes
Bearing oil is filled up to the indicated level: <i>Please mark the level in the sight glass circle on the right</i>	 Sight Glass
Lubrication rings rotate freely:	<input type="checkbox"/> no <input type="checkbox"/> yes

4.2 Flood lubrication

Bearing oil:	Manufacturer: _____ Type: _____
The oil quality is the same as recommended:	<input type="checkbox"/> no <input type="checkbox"/> yes
Lubrication rings rotate freely:	<input type="checkbox"/> no <input type="checkbox"/> yes
Flood lubrication oil pressure:	_____ kPa
Oil flow:	_____ liters/min
Rotation of the pumps checked:	<input type="checkbox"/> no <input type="checkbox"/> yes
Jack-up pumps checked:	<input type="checkbox"/> no <input type="checkbox"/> yes, alarm setting: _____ kPa, relief valve setting: _____ kPa
Oil filters checked:	<input type="checkbox"/> no <input type="checkbox"/> yes

4.3 Grease lubricated bearings:

Grease:	Manufacturer: _____ Type: _____
The grease quality is the same as recommended on the bearing plate:	<input type="checkbox"/> no <input type="checkbox"/> yes
The first greasing has been done:	Date: _____ Quantity: _____ g
Comments: 	

5 Electrical installation

Network variation:	<input type="checkbox"/> no <input type="checkbox"/> yes, voltage: _____ - _____ V, frequency: _____ - _____ Hz
Space heater operation:	<input type="checkbox"/> no <input type="checkbox"/> manual <input type="checkbox"/> automatic, controlled by: _____
Space heater for slip ring unit:	<input type="checkbox"/> no <input type="checkbox"/> yes, voltage: _____ V, power: _____ W

5.1 Insulation resistance test

Stator winding (1 min., 1000 VDC):	_____ M Ω , tested by _____ kV, winding temperature: _____ °C
Stator winding (15 / 60 s. or 1 / 10 min.):	PI = _____, tested by _____ kV, winding temperature: _____ °C
Rotor winding (1 min.):	_____ M Ω , tested by _____ kV, winding temperature: _____ °C
Exciter stator (1 min., 500 VDC):	_____ M Ω , tested by _____ kV, winding temperature: _____ °C
Space heater:	_____ M Ω (500 VDC)
Temperature detectors:	_____ M Ω (100 VDC)
N-end bearing insulation:	_____ M Ω (100 VDC)

5.2 Accessories resistance test

Stator 1 Pt 100:	_____ Ω
Stator 2 Pt 100:	_____ Ω
Stator 3 Pt 100:	_____ Ω
Stator 4 Pt 100:	_____ Ω
Stator 5 Pt 100:	_____ Ω
Stator 6 Pt 100:	_____ Ω
Bearing Pt 100 D-end:	_____ Ω
Bearing Pt 100 N-end:	_____ Ω
Air temperature 1 Pt 100:	_____ Ω
Air temperature 2 Pt 100:	_____ Ω
Anti-condensation heater:	_____ Ω



6 Machine protection settings

Overcurrent tripping:	_____ A _____ s
Instant overcurrent tripping:	_____ A _____ s
Overvoltage setting:	<input type="checkbox"/> no <input type="checkbox"/> yes, setting: _____
Earth fault setting:	<input type="checkbox"/> no <input type="checkbox"/> yes, setting: _____
Reverse power setting:	<input type="checkbox"/> no <input type="checkbox"/> yes, setting: _____
Differential protection setting:	<input type="checkbox"/> no <input type="checkbox"/> yes, setting: _____
Vibration monitoring:	<input type="checkbox"/> no <input type="checkbox"/> yes, alarm: _____ mm/s, trip: _____ mm/s
Temperature monitoring:	
- in stator winding	<input type="checkbox"/> no <input type="checkbox"/> yes, alarm: _____ °C, trip: _____ °C
- in bearing	<input type="checkbox"/> no <input type="checkbox"/> yes, alarm: _____ °C, trip: _____ °C
- in _____	<input type="checkbox"/> no <input type="checkbox"/> yes, alarm: _____ °C, trip: _____ °C
Other protection units:	<input type="checkbox"/> no <input type="checkbox"/> yes, type: _____

7 Test Run

7.1 First start (a few seconds only)

Note: Check that possible flood lubrication is on!

Direction of rotation (viewed from D-end):	<input type="checkbox"/>  CW	<input type="checkbox"/>  CCW
Are there abnormal noises?	<input type="checkbox"/> no <input type="checkbox"/> yes, from:	

7.2 Second start (uncoupled, if possible)

Note: Check that possible flood lubrication is on!

Are there abnormal noises?	<input type="checkbox"/> no <input type="checkbox"/> yes, from:
Does the machine vibrate abnormally?	<input type="checkbox"/> no <input type="checkbox"/> yes, where/how:
Bearing vibration level measured:	D-end: _____ mm/s, rms; N-end: _____ mm/s, rms
Running:	<input type="checkbox"/> machine run OK <input type="checkbox"/> operation stops, why:

Checking schedule and information

Time h:min	Bearing temperature		Bearing vibration levels		Stator			Stator winding temperature		
	D-end °C	N-end °C	D-end mm/s rms	N-end mm/s rms	Current A	Power Factor cos ϕ	Excit. Current A	U °C	V °C	W °C
0:00										
0:05										
0:10										
0:15										
0:20										

Comments:
Observations:

8 Test run (with load)

Checking schedule and information

Time	Load	Bearing temp.		Bearing vibration levels		Stator			Stator winding temperature		
		D-end	N-end	D-end mm/s	N-end mm/s	Current	Power Factor	Excit. Current	U	V	W
h:min	%	°C	°C	rms	rms	A	cos φ	A	°C	°C	°C
0:00											

Vibration spectrum attached:	<input type="checkbox"/> no <input type="checkbox"/> yes
Acceleration time:	_____ s.
Cooling air temperature:	Inlet: _____ °C Outlet: _____ °C
Cooling water temperature:	Inlet: _____ °C Outlet: _____ °C
Comments:	

9 Machine approval

Machine approved for use	Date:
Commissioning done by:	
Approved by:	

Fax Cover Sheet

Date:	
To:	ABB Oy Telefax: +358 (0) 10 22 22544
From:	
Fax number:	
Phone number:	
Email:	
Number of pages:	1 + 9 + _____

Message:

Typical position of plates

AMA, AMB, AMI

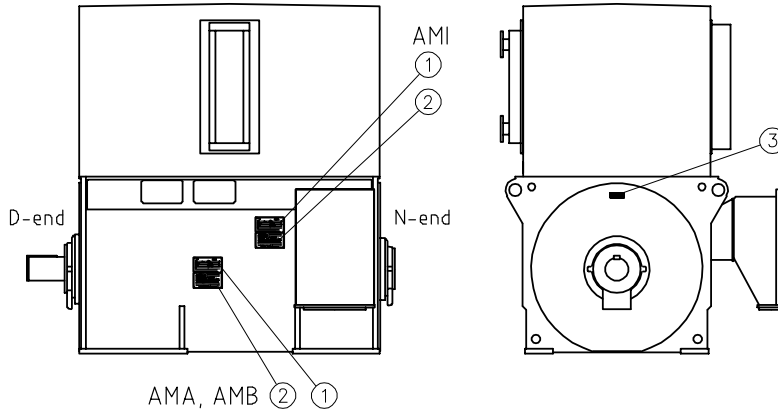

HXR
Horizontally mounted

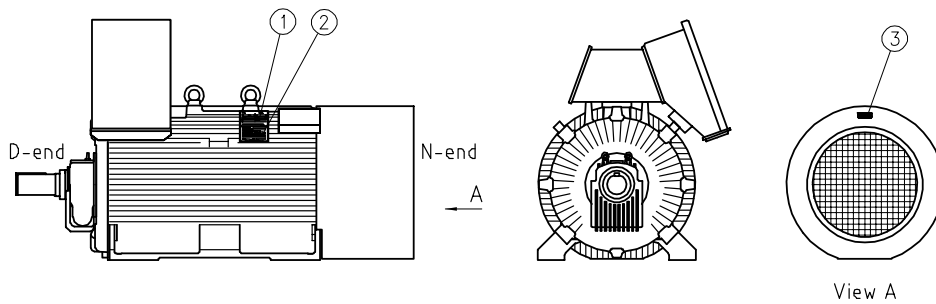

HXR
Vertically mounted

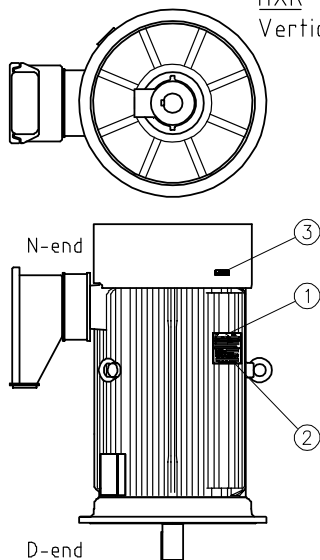

① Rating plate of the machine
 ② Bearing plate of the machine
 ③ Marking plate for direction of rotation

Direction of rotation seen from the drive end towards the machine:

Clockwise Counter-clockwise Reversing operation

Machine ends:
 D-end = drive end
 N-end = non-drive end

Typical main power cable connections

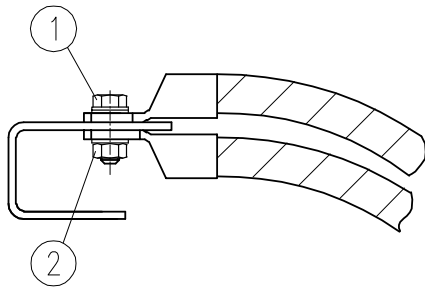

CONNECTION SCREW M12

- ① Screw: M12-steel
 - ② Hexagon nut: M12-steel
- Tightening torque 55 Nm.

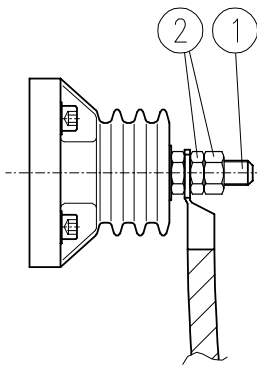

CONNECTION SCREW

- ① Screw: M16-bronze
 - ② Hexagon nut: M16-brass
- Tightening torque 40 Nm.

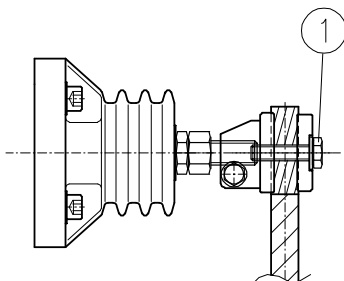

ROUND-TERMINAL: DIN 46223

- ① Screw: M10-steel
- Tightened until a reliable connection is obtained

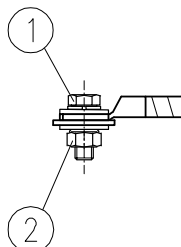

EARTHING SCREW M12

- ① Screw: M12 - AISI 316
 - ② Hexagon nut: M12-AISI 316
- Tightening torque 55 Nm. Do not tighten with machine.
It is recommended to use grease with spring locked nuts.



ABB Oy
Machines
P.O. Box 186
FIN-00381 HELSINKI
FINLAND
Telephone + 358 (0)10 2211
Telefax + 358 (0)10 22 22141
www.abb.com/motors&drives

3BFP 000 050 R0101 REV E

December 2006